

## Installation manual Cascade system

Quinta Ace  $\leq 115$   
Quinta Ace 160

Dear Customer,

Thank you very much for buying this appliance. Please read through the manual carefully before using the product, and keep it in a safe place for later reference. We hope you enjoy years of problem-free operation with the product.

# Contents

<b>1</b>	<b>Safety</b>	<b>4</b>
1.1	Liabilities	4
1.1.1	Manufacturer's liability	4
1.1.2	Installer's liability	4
1.1.3	User's liability	4
<b>2</b>	<b>About this manual</b>	<b>4</b>
2.1	General	4
2.2	Additional documentation	4
2.3	Symbols used	4
2.3.1	Symbols used in the manual	4
<b>3</b>	<b>Description of the product</b>	<b>5</b>
3.1	Main components	5
3.2	Cascade types	6
<b>4</b>	<b>Before installation</b>	<b>6</b>
4.1	Installation regulations	6
4.2	Requirements for water connections	6
4.2.1	Requirements for the central heating connections	6
4.2.2	Requirements for the condensate drain	7
4.2.3	Requirements for expansion vessels	7
4.3	Choosing a plate heat exchanger type	7
4.4	Requirements for the gas connection	7
4.5	Requirements on the flue gas discharge system	7
4.5.1	Material	7
4.5.2	Additional guidelines	8
4.6	Water quality and water treatment	9
4.7	Choice of the location	9
4.7.1	Boiler room	9
<b>5</b>	<b>Installation</b>	<b>10</b>
5.1	General	10
5.2	Assembly	10
5.2.1	Mounting the wall bracket	10
5.2.2	Assembling the frames	11
5.2.3	Assembling the collector pipes	11
5.2.4	Installing and connecting the boilers - wall hung type	12
5.2.5	Installing and connecting the boilers - standing type	13
5.3	Hydraulic connections	15
5.3.1	Installing a bend set	15
5.3.2	Installing an adapter plate for the low loss header	15
5.3.3	Installing a low loss header	15
5.3.4	Installing a plate heat exchanger	16
5.4	Air inlet/flue gas outlet connections	19
5.5	Fitting insulation modules	19
5.6	Gas connection	21
5.6.1	Installing the gas filter	21
5.7	Completing the installation	21
<b>6</b>	<b>Commissioning</b>	<b>21</b>
6.1	Commissioning procedure	21
<b>7</b>	<b>Technical specifications</b>	<b>22</b>
7.1	Technical data - Plate heat exchanger	22
7.2	Dimensions and connections	22
7.2.1	Dimensions and connections - Cascade setup	22
7.2.2	Dimensions and connections - Low loss headers	25
7.2.3	Dimensions and connections - Plate heat exchangers	27

# 1 Safety

---

## 1.1 Liabilities

---

### 1.1.1 Manufacturer's liability

---

Our products are manufactured in compliance with the requirements of the various directives applicable. They are therefore delivered with the <sup>UK</sup> **CA** and **CE** marking and any documents necessary. In the interests of the quality of our products, we strive constantly to improve them. We therefore reserve the right to modify the specifications given in this document.

Our liability as manufacturer may not be invoked in the following cases:

- Failure to abide by the instructions on installing and maintaining the product.
- Failure to abide by the instructions on using the product.
- Faulty or insufficient maintenance of the product.

### 1.1.2 Installer's liability

---

The installer is responsible for the installation and initial commissioning of the product. The installer must observe the following instructions:

- Read and follow the instructions given in the manuals provided with the product.
- Install the product in compliance with prevailing legislation and standards.
- Carry out initial commissioning and any checks necessary.
- Explain the installation to the user.
- If maintenance is necessary, warn the user of the obligation to check the product and keep it in good working order.
- Give all the instruction manuals to the user.

### 1.1.3 User's liability

---

To guarantee optimum operation of the system, you must abide by the following instructions:

- Read and follow the instructions given in the manuals provided with the product.
- Call on a qualified professional to carry out the installation and initial commissioning.
- Have your installer explain the installation to you.
- Have the required inspections and maintenance carried out by a qualified installer.
- Keep the instruction manuals in good condition and close to the product.

# 2 About this manual

---

## 2.1 General

---

This manual is intended for the installer.



### Important

Some illustrations in this manual show parts that may not be available in your market.

## 2.2 Additional documentation

---

## 2.3 Symbols used

---

### 2.3.1 Symbols used in the manual

---

This manual contains special instructions, marked with specific symbols. Please pay extra attention when these symbols are used.

**Danger**

Risk of dangerous situations that may result in serious personal injury.

**Warning**

Risk of dangerous situations that may result in minor personal injury.

**Caution**

Risk of material damage.

**Important**

Please note: important information.

The symbols mentioned below are of lower importance, but they can help you navigate or give useful information.

**See**

Reference to other manuals or pages in this manual.

## 3 Description of the product

### 3.1 Main components

Fig.1 Main components of a cascade system

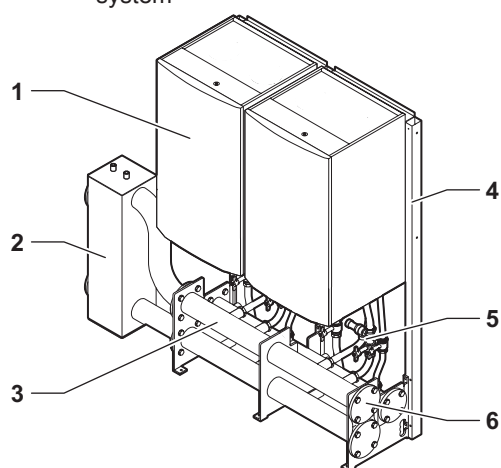

AD-3002461-01

- 1 Appliance
- 2 Hydraulic separator
- 3 Collector pipe
- 4 Mounting frame
- 5 Boiler connection set
- 6 Blanking flange

## 3.2 Cascade types

Tab.1 Cascade types

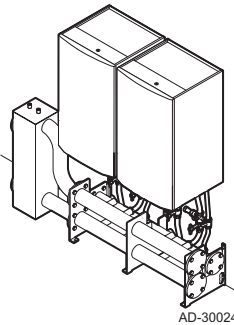
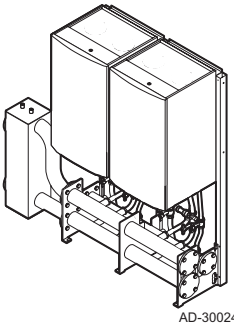
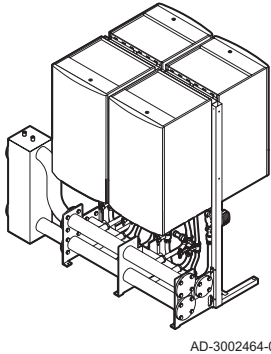
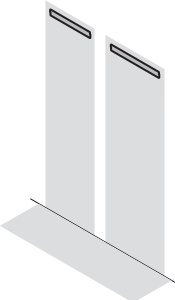
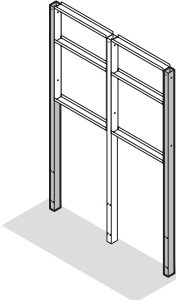
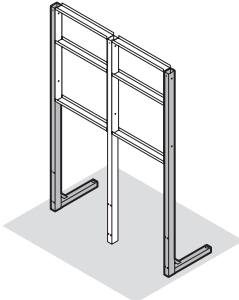
Cascade type	In-line wall mounted configuration	In-line standing configuration	Back-to-back configuration
Description	Boilers in line, mounted to the wall. The collector pipe assembly is mounted to the wall. The frame consists of wall brackets.	Boilers in line, mounted to the frame. The collector pipe assembly is mounted to the frame. The frame consists of I-poles.	Boilers back to back, mounted to the frame. The collector pipe assembly is mounted to the frame. The frame consists of I-poles and L-poles.
Example	 AD-3002462-01	 AD-3002463-01	 AD-3002464-01
Frame type	 AD-3002465-01	 AD-3002466-01	 AD-3002467-01



### Caution

It is not allowed to use an in-line standing frame for a back-to-back configuration.

## 4 Before installation

### 4.1 Installation regulations



### Warning

The installer must be registered with Gas Safe and have the correct ACS qualifications.



### Important

Practical guidelines - see the latest version.

### 4.2 Requirements for water connections

- Before installation, check that the connections meet the set requirements.
- Carry out any welding work required at a safe distance from the boiler.
- If using synthetic pipes, follow the manufacturer's instructions.

#### 4.2.1 Requirements for the central heating connections

- We recommend installing a central heating filter in the return pipe to prevent clogging of boiler components.

## 4.2.2 Requirements for the condensate drain

- The drain pipe must be  $\varnothing$  32 mm or larger, terminating in the drain.
- Use only plastic material for the discharge pipe due to the acidity (pH 2 to 5) of the condensate.
- Fit a trap in the drain pipe.
- The drain pipe must slope down at least 30 mm per metre, the maximum horizontal length is 5 metres.
- Do not make a fixed connection in order to prevent an overpressure in the trap.

## 4.2.3 Requirements for expansion vessels



### Caution

The installer is responsible for determining the correct expansion vessel size.

An expansion vessel must be installed at each boiler that has a calorifier connection kit.

When a plate heat exchanger is installed, an additional expansion vessel must be fitted on the boiler side of the heat exchanger. A blanking flange set with an expansion vessel connection is available separately for this purpose.

## 4.3 Choosing a plate heat exchanger type

A plate heat exchanger can be used as a hydraulic separator. Refer to the following table to determine the correct plate heat exchanger type.

Tab.2 Plate heat exchanger per boiler type

Number of boilers	Quinta Ace $\leq$ 115 - 45	Quinta Ace $\leq$ 115 - 65	Quinta Ace $\leq$ 115 - 90	Quinta Ace $\leq$ 115 - 115	Quinta Ace 160 - 160
2	RHB-60-60	RHB-60-80	RHB-60-80	RHB-110-100	RHB-110-80
3	RHB-60-60	RHB-60-120	RHB-60-140	RMB-235-80	RHB-110-140
4	RHB-60-80	RHB-110-80	RHB-110-80	RMB-235-100	RMB-235-80
5	RHB-60-100	RHB-110-100	RHB-110-120	RMB-235-120	RMB-235-100
6	RHB-60-140	RHB-110-120	RHB-110-140	RMB-235-160	RMB-235-140
7	RHB-110-80	RHB-110-160	RMB-235-80	RMB-235-180	RMB-235-160
8	RHB-110-80	RMB-235-80	RMB-235-100	RMB-235-220	RMB-235-180
9	RHB-110-100	RMB-235-80	RMB-235-100	RMB-235-280	-
10	RHB-110-120	RMB-235-80	RMB-235-120	RMB-235-280	-

## 4.4 Requirements for the gas connection

- Carry out any welding work required at a safe distance from the boiler.
- Before installing, check that the gas meter has sufficient capacity. Take into account the consumption of all appliances. Notify the local energy company if the gas meter has insufficient capacity.
- We recommend installing a gas filter to prevent clogging of the gas valve unit.

## 4.5 Requirements on the flue gas discharge system

### 4.5.1 Material

Use the string on the flue gas outlet material to check whether it is suitable for use on this appliance.

Fig.2 Sample string

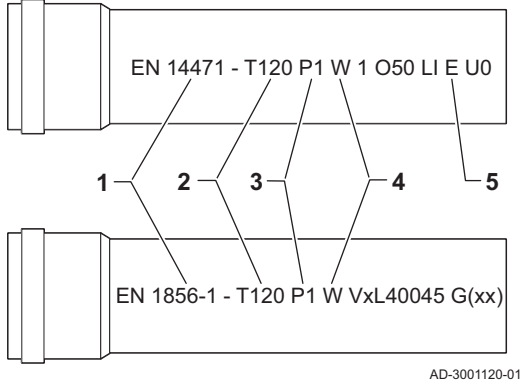

- 1 **EN 14471 or EN 1856-1**: The material is UKCA and CE approved according to this standard. For plastic this is EN 14471, For aluminium and stainless steel this is EN 1856-1.
- 2 **T120**: The material has temperature class T120. A higher number is also allowed, but not lower.
- 3 **P1**: The material falls into pressure class P1. H1 is also allowed.
- 4 **W**: The material is suitable for draining condensation water (W='wet'). D is not allowed (D='dry').
- 5 **E**: The material falls into fire resistance class E. Class A to D are also allowed, F is not allowed. Only applicable to plastic.



**Warning**

- The coupling and connection methods may vary depending on the manufacturer. It is not permitted to combine pipes, coupling and connection methods from different manufacturers. This also applies to roof terminal and common shared flue ducts.
- The materials used must comply with the prevailing regulations and standards.
- Please contact us to discuss using flexible flue gas outlet material.

Tab.3 Overview of material properties

Version	Flue gas outlet		Air supply	
	Material	Material properties	Material	Material properties
Single-wall, rigid	<ul style="list-style-type: none"> <li>• Plastic<sup>(1)</sup></li> <li>• Stainless steel<sup>(2)</sup></li> <li>• Thick-walled, aluminium<sup>(2)</sup></li> </ul>	<ul style="list-style-type: none"> <li>• With UKCA and/or CE marking</li> <li>• Temperature class T120 or higher</li> <li>• Condensate class W (wet)</li> <li>• Pressure class P1 or H1</li> <li>• Fire resistance class E or better<sup>(3)</sup></li> </ul>	<ul style="list-style-type: none"> <li>• Plastic</li> <li>• Stainless steel</li> <li>• Aluminium</li> </ul>	<ul style="list-style-type: none"> <li>• With UKCA and/or CE marking</li> <li>• Pressure class P1 or H1</li> <li>• Fire resistance class E or better<sup>(3)</sup></li> </ul>
<p>(1) according to EN 14471                      (2) according to EN 1856                      (3) according to EN 13501-1</p>				

**4.5.2 Additional guidelines**

■ **Installation**



**Warning**

If the flue gas outlet and air supply materials are not installed in accordance with the instructions, this can result in dangerous situations and/or physical injury.

- For installing the flue gas outlet and air supply materials, refer to the instructions of the manufacturer of the material. After installation, check at least all flue gas outlet and air supply parts for tightness.
- Install the flue gas outlet pipe towards the boiler with a sufficient gradient (at least 50 mm per metre).
- Install a sufficient condensate collector and discharge at least 1 m before the outlet of the boiler.
- The bends used must be larger than 90° to guarantee the gradient and a good seal on the lip rings.

■ **Condensation**

- Direct connection of the flue gas outlet to structural ducts is not permitted because of condensation.
- If condensate from a plastic or stainless steel pipe section can flow back to an aluminium part in the flue gas outlet, this condensate must be discharged via a trap before it reaches the aluminium.



- Newly installed aluminium flue gas pipes with longer lengths can produce relatively larger quantities of corrosion products. Also casting sand and processing metal chips from new boilers can fill the boiler trap on short term after installation. Check and clean the trap more often for these reasons.

## 4.6 Water quality and water treatment

---

The quality of the heating water must comply with the limit values in our **Water quality instructions**. The guidelines in these instructions must be followed at all times. In many cases, the boiler and central heating system can be filled with normal tap water and water treatment will not be necessary.

## 4.7 Choice of the location

---

### 4.7.1 Boiler room

---



#### Caution

Always follow the requirements given in the installation manual of the boiler.

If the combined maximum load of the cascade system is higher than 130 kW, the boiler room must comply with specific regulations.



#### See

- The local regulations.
- BS6644: Specification for the installation and maintenance of gas-fired hot water boilers of rated inputs between 70 kW (net) and 1.8 MW (net)

## 5 Installation

### 5.1 General

Fig.3 Flange bolt tightening sequence

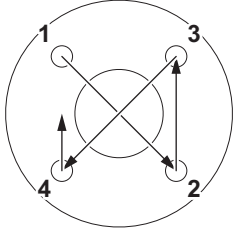

AD-3002638-01



**Warning**

The cascade system and the appliances must be installed by a qualified installer in accordance with local and national regulations.



**Warning**

When tightening flange bolts:

- Make sure that the given tightening torque is applied.
- Apply two tightening stages. For example: First tighten all the bolts with 20 N·m before tightening to the final torque of 40 N·m.
- Make sure that the bolts are tightened in a cross wise pattern, as shown in the image.



**Warning**

When tightening hydraulic and gas connections:

- Make sure that the given tightening torque is applied.
- Always perform a leak detection test before commissioning the installation.

### 5.2 Assembly

#### 5.2.1 Mounting the wall bracket

Fig.4 Mounting the wall bracket

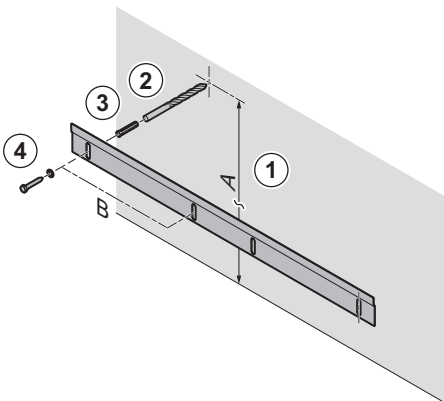

AD-3002516-01

Specific wall cascade brackets are available to support multiple boilers. When using the single brackets supplied with the boiler, refer to the boiler installation manual for the mounting instructions.



**Caution**

Make sure that the wall is suitable for the weight of the boilers and their water content.

1. Determine the correct height and number of holes from the table.  
Tab.4 Boiler mounting strip height and number of holes (DN65 collector pipes)

Boiler type	A - Height	A - Height with calorifier set	B - Number of holes per boiler position
Quinta Ace ≤115	1747 mm	1847 mm	2
Quinta Ace 160	1968 mm	-	4

Tab.5 Boiler mounting strip height and number of holes (DN100 collector pipes)

Boiler type	A - Height	A - Height with calorifier set	B - Number of holes per boiler position
Quinta Ace ≤115	1747 mm	1847 mm	2
Quinta Ace 160	1968 mm	1968 mm	4

2. Drill the required number of holes with a 10 mm drill.
3. Insert the wall plugs.
4. Mount the bracket.

## 5.2.2 Assembling the frames

Fig.5 Assemble the frames

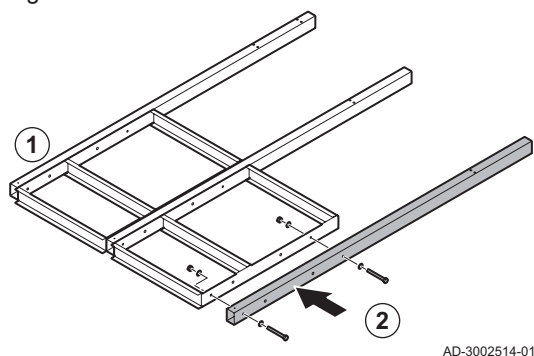

AD-3002514-01

Fig.6 Preparation for boiler connection

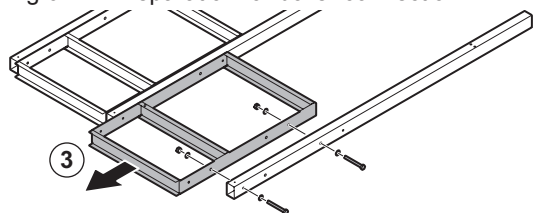

AD-3002658-01

Proceed as follows to assemble the cascade frames:

1. Put all the frame parts on the floor in the correct order.
2. Assemble the frame parts with the supplied bolts.

3. For a calorifier connection on a DN65 collector pipe set, mount the frame as indicated in the picture. This height adjustment is only required for the boiler position on which the calorifier connection will be made.

### ■ Installing the levelling feet (optional)

If the floor of the installation area is not flat, it is advised to install levelling feet. Levelling feet are only available for standing configurations.

Be aware that there are two types of levelling feet. Use the levelling feet with the extra nut for holes without thread. Continue as follows:

1. Screw in the levelling feet at the bottom of the I-poles and L-poles.
2. Insert the levelling feet with the extra nut at the end of the L-poles and collector tubes.

Fig.7 Insert the levelling feet

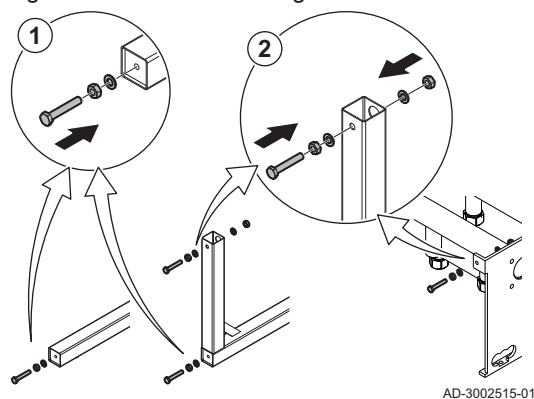

AD-3002515-01

## 5.2.3 Assembling the collector pipes



### Caution

Make sure all mounting surfaces are clean before assembling the collector pipes.

Proceed as follows to assemble the collector pipes:

Fig.8 Connect the segments

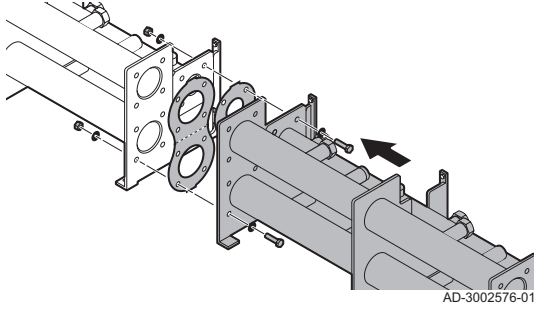

1. Connect the collector pipe segments.  
Tightening torque:
  - Flow and return pipe: 35 N·m
  - Gas pipe: 35 N·m

**Warning** Make sure to put gaskets in between the segments, for both the gas and hydraulic connections.

Fig.9 Install the connection set tubing

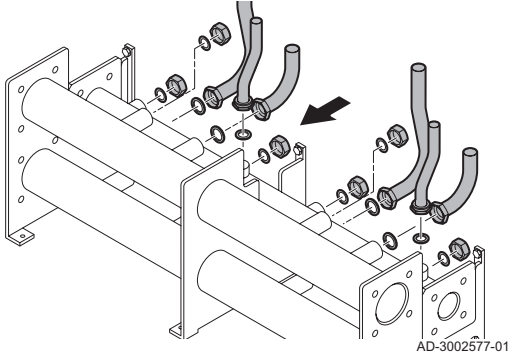

2. Install the bottom tubing and blanking caps of the connection sets.  
Tightening torque: Tighten by hand

Fig.10 Install the blanking flanges

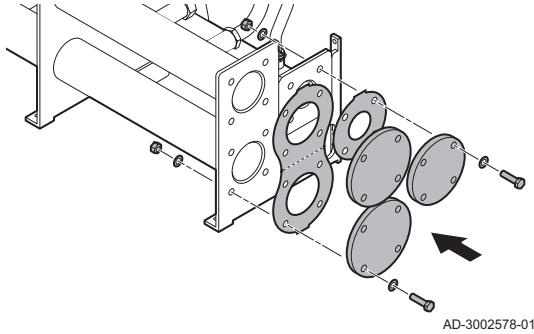

3. Install the blanking flanges on the end segment.
    - If a plate heat exchanger is to be installed, use a blanking flange with an expansion vessel connection.
- Tightening torque:
- Flow and return flange: 35 N·m
  - Gas flange: 35 N·m
4. Move the assembled collector pipe to its approximate location.

### 5.2.4 Installing and connecting the boilers - wall hung type

Fig.11 Screw the adapter pieces onto the boiler

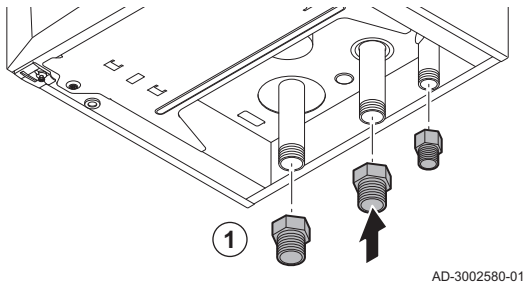

Proceed as follows to assemble the collector tubes:

1. Screw the adapter pieces onto the boiler connections.

**Caution** When working on the water connections of the boiler, water from the factory test can come out.

- Tightening torque:
- Water connection adapters: 30 N·m
  - Gas connection adapter: 30 N·m

Fig.12 Hang the boilers in place

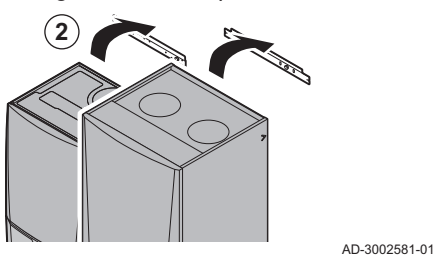

2. Hang the boilers in place.

Fig.13 Fasten the collector tubes

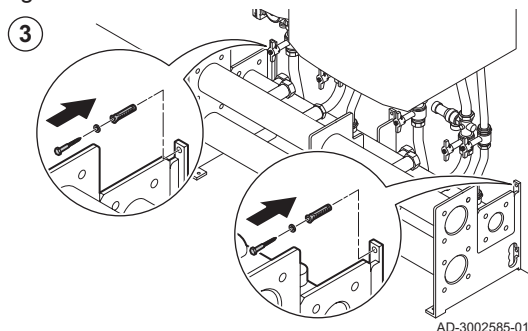

AD-3002585-01

3. Fasten the collector tubes to the wall.

Fig.14 Install the boiler connection sets

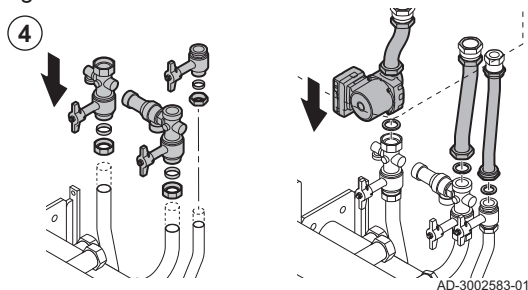

AD-3002583-01

4. Install the boiler connection sets.  
Depending on the configuration, the bottom connector pipes need to be shortened.  
Tightening torque: Tighten by hand

Fig.15 Tightening torques

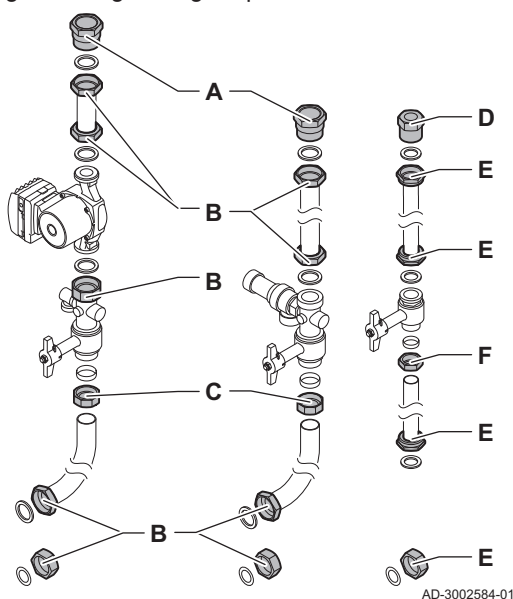

AD-3002584-01

5. Tighten all the connections with the torques specified in the table.

Tab.6 Tightening torques

Item	Tightening torque
A	30 N·m
B	30 N·m
C	Hand tight + 3/4 turn
D	30 N·m
E	15 N·m
F	Hand tight + 3/4 turn

### 5.2.5 Installing and connecting the boilers - standing type

Fig.16 Screw the adapter pieces onto the boiler

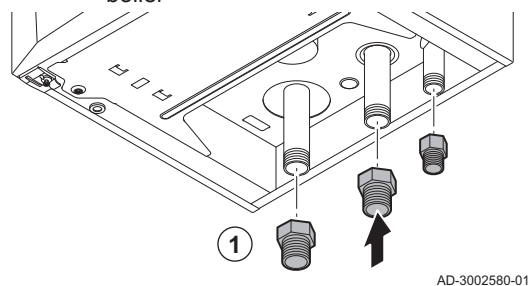

AD-3002580-01

Proceed as follows to assemble the collector tubes:

1. Screw the adapter pieces onto the boiler connections.



**Caution**

When working on the water connections of the boiler, water from the factory test can come out.

Tightening torque:

- Water connection adapters: 30 N·m
- Gas connection adapter: 30 N·m

Fig.17 Mount the collector pipes

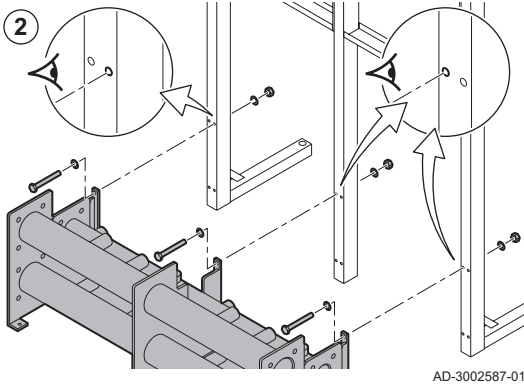

AD-3002587-01

2. Mount the collector pipes to the frames.

Fig.18 Place the boilers on the frames

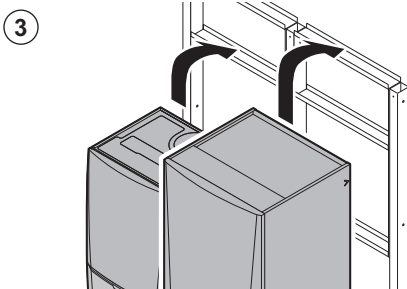

AD-3002588-01

3. Place the boilers on the frames.

Fig.19 Install the connection sets

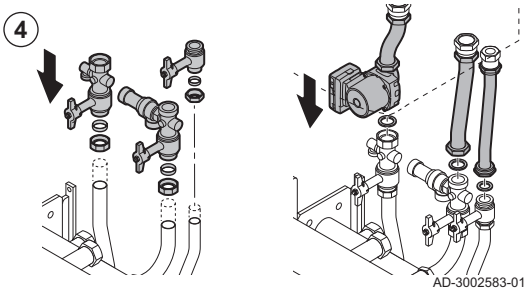

AD-3002583-01

4. Install the connection sets.  
Depending on the configuration, the bottom connector pipes need to be shortened.  
Tightening torque: Tighten by hand

Fig.20 Tightening torques

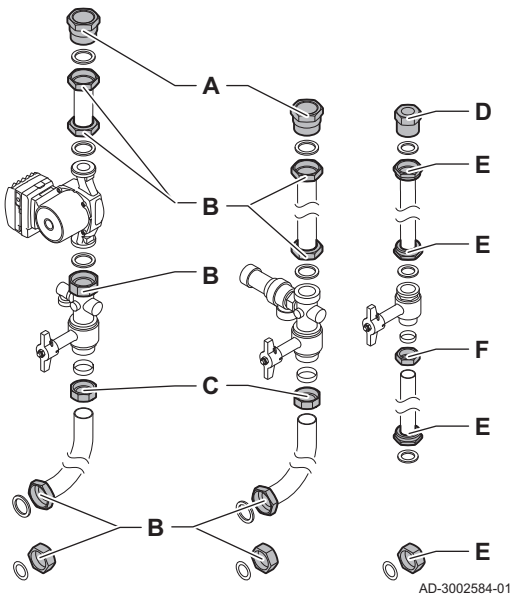

AD-3002584-01

5. Tighten all the connections with the tightening torques specified in the table.

Tab.7 Tightening torques

Item	Tightening torque
A	30 N·m
B	30 N·m
C	Hand tight + 3/4 turn
D	30 N·m
E	15 N·m
F	Hand tight + 3/4 turn

If installed, use the levelling feet to level the cascade setup before proceeding to the next chapter.

## 5.3 Hydraulic connections

### 5.3.1 Installing a bend set

A bend set can be installed to allow a different routing of the flow and return pipes. Proceed as follows to install the bend set:

Fig.21 Install the extension tube

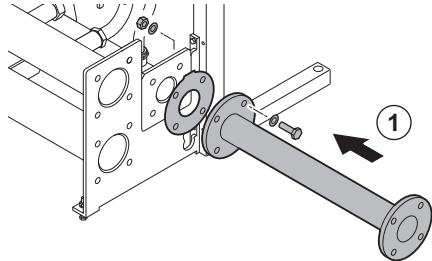

AD-3002589-01

1. Install the extension tube for the gas filter.  
Tightening torque: 35 N·m

Fig.22 Install the bend set

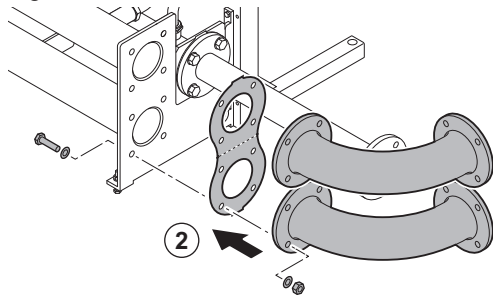

AD-3002590-01

2. Install the bend set.  
Tightening torque: 35 N·m

### 5.3.2 Installing an adapter plate for the low loss header

A DN65 low loss header can be fitted to a DN100 collector pipe set. In that case, an adapter plate must be installed.

Proceed as follows to install the adapter plate:

Fig.23 Install the adapter plate

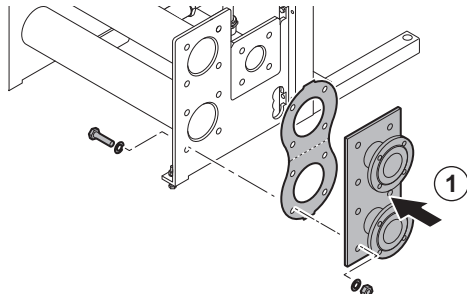

AD-3002636-01

1. Install the adapter plate.  
Tightening torque: 35 N·m

### 5.3.3 Installing a low loss header

Proceed as follows to install the low loss header:

Fig.24 Install the low loss header

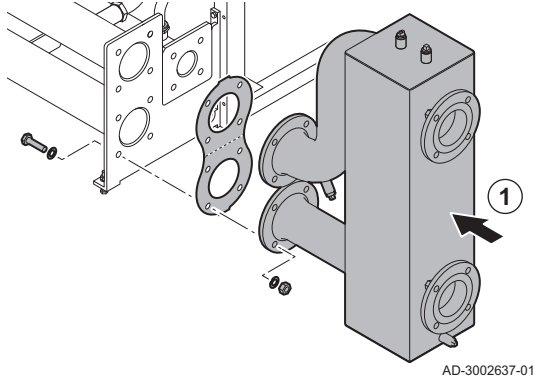

1. Install the low loss header.  
Tightening torque: 35 N·m

### 5.3.4 Installing a plate heat exchanger

The installation procedure differs per plate heat exchanger type:

Tab.8 Heat exchanger mounting

Type	Floor mounting base	Connection type
RHB-60	no	Outer thread 1 1/4"
RHB-110	yes	Outer thread 2"
RMB-235	yes	DN80

1. Remove as much of the packaging material as possible.
2. Prepare the heat exchanger (only for types with floor mounting base):
  - 2.1. Mount the lifting brackets.
  - 2.2. Carefully lift up the heat exchanger.

Fig.25 Mount the lifting brackets

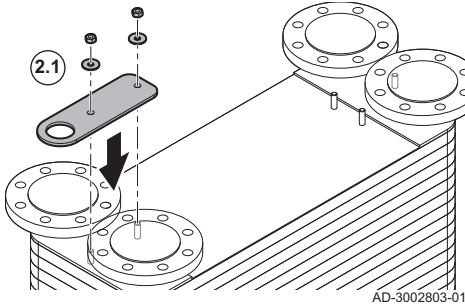
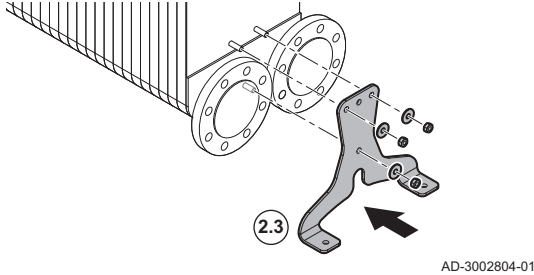
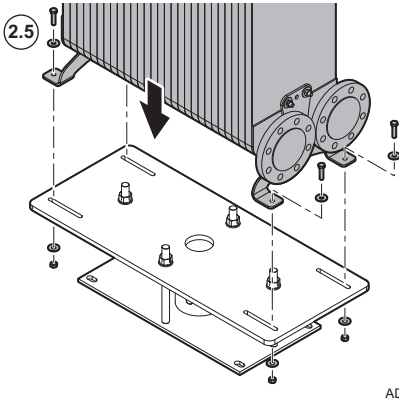

Fig.26 Mount the legs



- 2.3. Mount the legs on both sides.

Fig.27 Place the heat exchanger



- 2.4. Lift the heat exchanger onto the base.
- 2.5. Fasten the legs to the base.



Fig.28 Mount the connection set

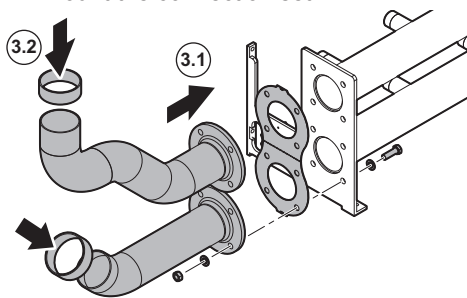

AD-3002856-01

3. Mount the connection set pipes:
  - 3.1. Mount the bottom part to the collector tubes.
  - 3.2. Mount the rubber gasket.

Fig.29 Mount the connection set

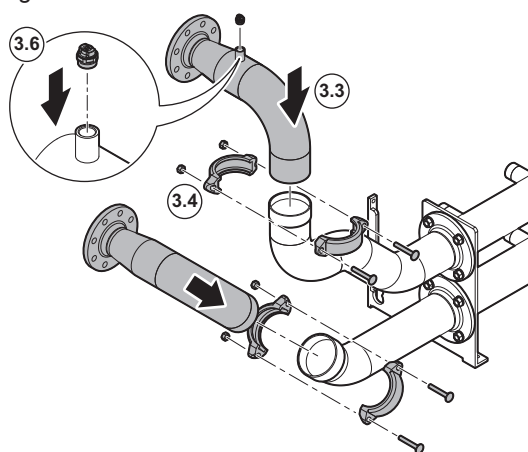

AD-3002857-02

- 3.3. Insert the top part into the rubber gasket and hold it in place.
- 3.4. Mount the clamp around the rubber part.
- 3.5. Repeat the previous steps for the other pipe.
- 3.6. Install the bleed valve on the top pipe.

Fig.30 Prepare the holes

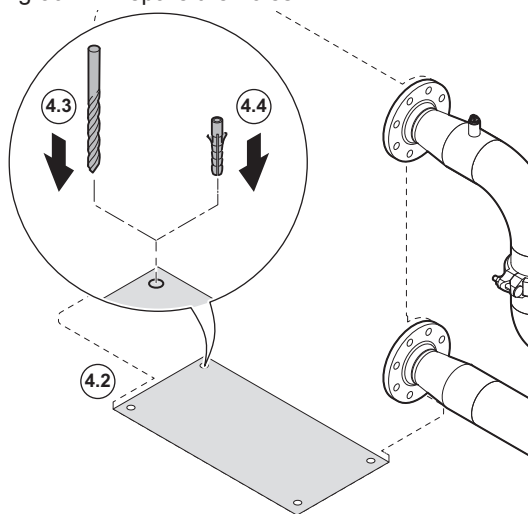

AD-3002858-02

4. Mount the base plate:
  - 4.1. Position the heat exchanger based on the connection set.
  - 4.2. Mark the holes on the ground.
  - 4.3. Drill the holes.
  - 4.4. Insert the plugs (if required).

Fig.31 Place the heat exchanger

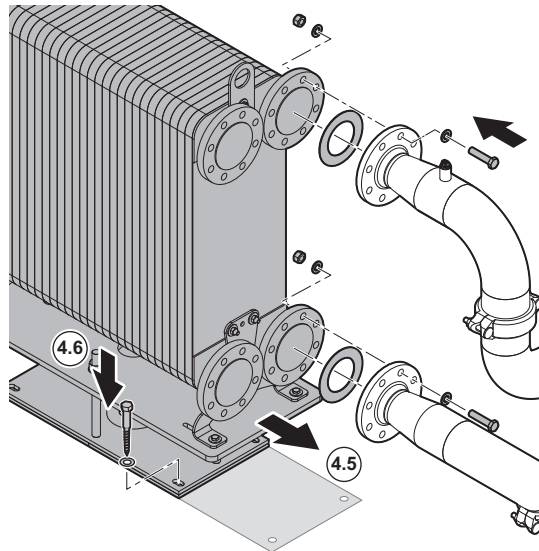

AD-3002918-02

- 4.5. Put the heat exchanger in place.
- 4.6. Mount the base to the ground using suitable fasteners.

Fig.32 Tighten all connections

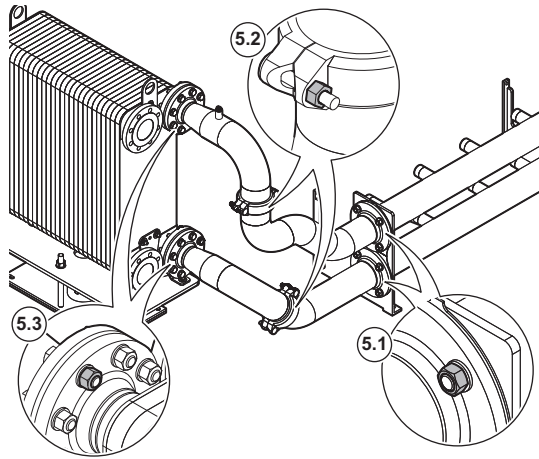

AD-3002919-02

- 5. Tighten all connections:  
Work from the collector tubes towards the heat exchanger.
- 5.1. Tighten the flange connections on the collector tubes.
- 5.2. Tighten the pipe clamps.
- 5.3. Tighten the heat exchanger connections.

Fig.33 Adjust the height

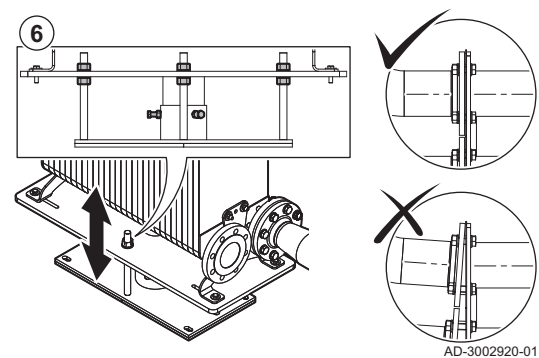

AD-3002920-01

- 6. Carefully adjust the height and position of the heat exchanger until all connections are free of tension.

Fig.34 Place the insulation

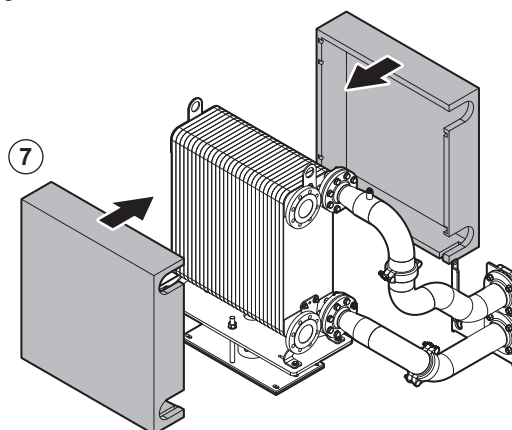

AD-3003026-02

7. Place the insulation.
8. Insulate the connection set.

## 5.4 Air inlet/flue gas outlet connections

Refer to the data plate and the boiler documentation for the available flue configurations.

## 5.5 Fitting insulation modules

If no bend set is installed, fit the insulation for the low loss header before installing the gas connection. The other insulation modules can be fitted after the final assembly.

Proceed as follows:

Fig.35 Fit the collector pipe insulation

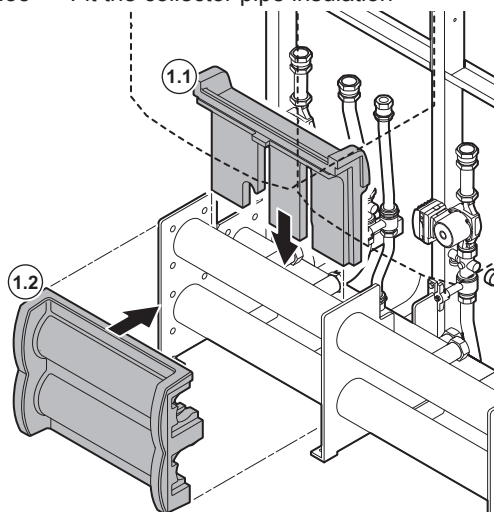

AD-3002649-01

1. Fit the insulation on each of the collector pipes:
  - 1.1. Fit the rear module.
  - 1.2. Fit the front module.

Fig.36 Fit the connection set insulation

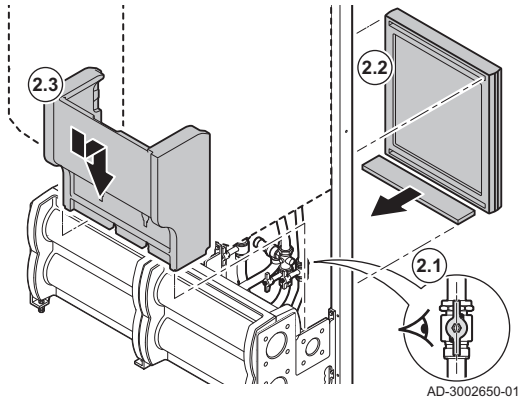

2. Fit the insulation on each of the connection sets:
  - 2.1. Make sure the valves are opened.
  - 2.2. Fit the rear panel with the strips as shown in the image.
  - 2.3. Fit the front module.
  - 2.4. Fit the rear module (back-to-back configuration).

Fig.37 Fit the connection set insulation (Back-to-back configuration)

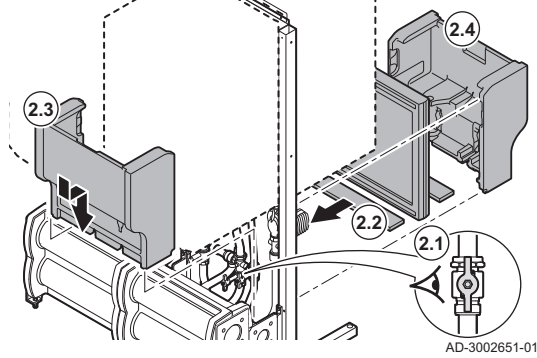
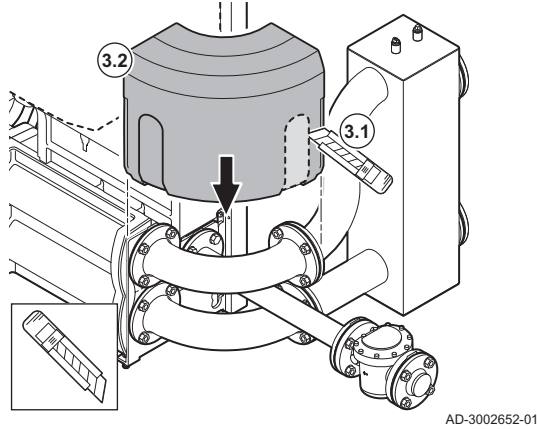
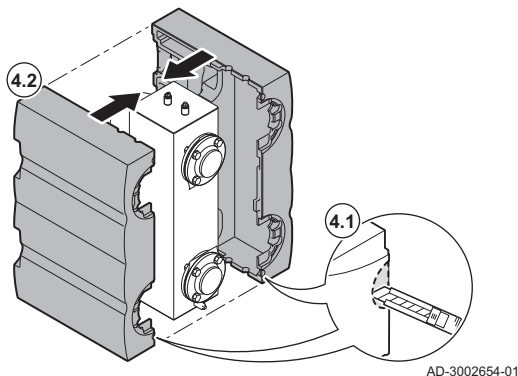

Fig.38 Fit the bend set insulation



3. Fit the insulation for the bend set (if applicable):
  - 3.1. Make a cutout for the gas tube.
  - 3.2. Fit the bend module.

Fig.39 Fit the low loss header insulation (DN100)



AD-3002654-01

4. Fit the insulation for the low loss header:
  - 4.1. Make the cutouts as shown in the image.
  - 4.2. Fit the insulation modules on the low loss header.
  - 4.3. Fit the extra insulation piece on the adapter (if applicable).

Fig.40 Fit the low loss header insulation (DN65)

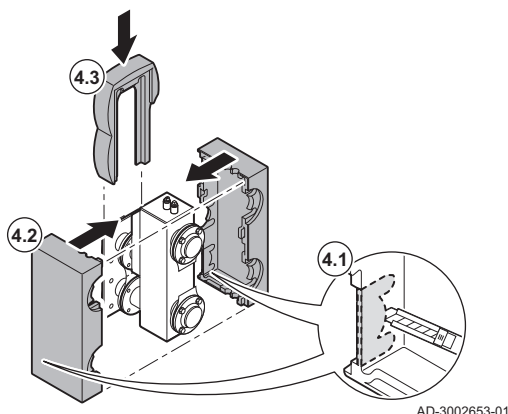

AD-3002653-01

## 5.6 Gas connection

### 5.6.1 Installing the gas filter

Fig.41 Install the gas filter

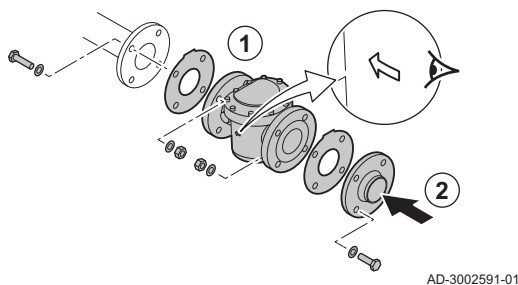

AD-3002591-01

Proceed as follows to install the gas filter:

1. Install the gas filter.  
Make sure that the flow direction of the gas filter is correct.  
Tightening torque: 35 N·m
2. Install the gas flange.  
Tightening torque: 35 N·m

## 5.7 Completing the installation

1. Connect the cascade to the heating installation.
2. Perform the required installation steps from the manuals of the boilers.
3. Perform the required installation steps from the manual of the controller.
4. Connect the cascade to the gas supply.
5. Fill the heating installation with water.

## 6 Commissioning

### 6.1 Commissioning procedure

1. Perform a leak detection test on the gas connections.

2. Perform a pressurised leak detection test on the water connections. Use cold water at a pressure that is 1.3 times the intended working pressure of the system.
3. If a plate heat exchanger is installed, deaerate the primary side using the valve on the heat exchanger connection set.
4. Perform the commissioning steps on the boilers as described in their manuals.

## 7 Technical specifications

---

### 7.1 Technical data - Plate heat exchanger

---

Tab.9 Technical data

Heat exchanger type	Heat load in kW	Pressure drop in kPa	Flow in m <sup>3</sup> /h
RHB-60-60	84.4	4.46	2.90
RHB-60-80	179.0	18.48	6.16
RHB-60-100	211.0	18.47	7.26
RHB-60-120	195.0	13.19	6.71
RHB-60-140	268.5	17.47	9.24
RHB-110-80	358.0	22.09	12.32
RHB-110-100	379.8	16.81	13.07
RHB-110-120	447.5	17.99	15.39
RHB-110-140	484.8	16.53	16.68
RHB-110-160	455.0	12.09	15.65
RMB-235-80	650.0	18.93	22.36
RMB-235-100	808.0	19.06	27.80
RMB-235-120	895.0	17.74	30.79
RMB-235-140	969.6	15.90	33.35
RMB-235-160	1131.2	17.17	38.91
RMB-235-180	1292.8	18.51	44.47
RMB-235-220	877.6	10.22	37.74
RMB-235-280	1097.0	11.83	47.17

### 7.2 Dimensions and connections

---

#### 7.2.1 Dimensions and connections - Cascade setup

---

The images in this chapter show DN100 collector pipes.

Fig.42 In-line wall mounted configuration

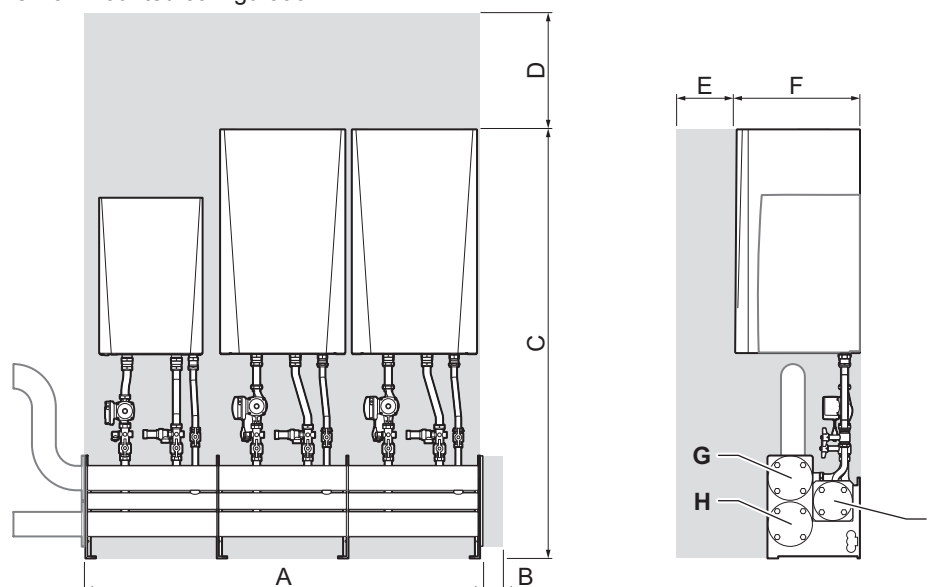

AD-3003035-01

Tab.10 Dimensions in mm with DN65 collector pipes

	Description	2 boilers	3 boilers	4 boilers	5 boilers	6 boilers	7 boilers	8 boilers
A	Total width	1060	1590	2120	2650	3180	3710	4240
B	Free space required for mounting the blanking flanges <sup>(1)</sup>	50	50	50	50	50	50	50
C	Total height	1576	1576	1576	1576	1576	1576	1576
D	Free space above the boilers (recommended)	500	500	500	500	500	500	500
E	Free space in front of the boilers (recommended)	1000	1000	1000	1000	1000	1000	1000
F	Total depth	520	520	520	520	520	520	520
G	Flow connection	DN65 PN6	DN65 PN6	DN65 PN6	DN65 PN6	DN65 PN6	DN65 PN6	DN65 PN6
H	Return connection	DN65 PN6	DN65 PN6	DN65 PN6	DN65 PN6	DN65 PN6	DN65 PN6	DN65 PN6
I	Gas connection	DN50 PN16	DN50 PN16	DN50 PN16	DN50 PN16	DN50 PN16	DN50 PN16	DN50 PN16

(1) When fitting a blanking flange with an expansion vessel connection, make sure there is enough space for fitting the vessel.

Tab.11 Dimensions in mm with DN100 collector pipes

	Description	2 boilers	3 boilers	4 boilers	5 boilers	6 boilers	7 boilers	8 boilers
A	Total width	1260	1890	2520	3150	3780	4410	5040
B	Free space required for mounting the blanking flanges <sup>(1)</sup>	55	55	55	55	55	55	55
C	Total height	2004	2004	2004	2004	2004	2004	2004
D	Free space above the boilers (recommended)	500	500	500	500	500	500	500
E	Free space in front of the boilers (recommended)	1000	1000	1000	1000	1000	1000	1000
F	Total depth	602	602	602	602	602	602	602
G	Flow connection	DN100 PN6	DN100 PN6	DN100 PN6	DN100 PN6	DN100 PN6	DN100 PN6	DN100 PN6
H	Return connection	DN100 PN6	DN100 PN6	DN100 PN6	DN100 PN6	DN100 PN6	DN100 PN6	DN100 PN6
I	Gas connection	DN65 PN16	DN65 PN16	DN65 PN16	DN65 PN16	DN65 PN16	DN65 PN16	DN65 PN16

(1) When fitting a blanking flange with an expansion vessel connection, make sure there is enough space for fitting the vessel.

Fig.43 In-line frame mounted configuration

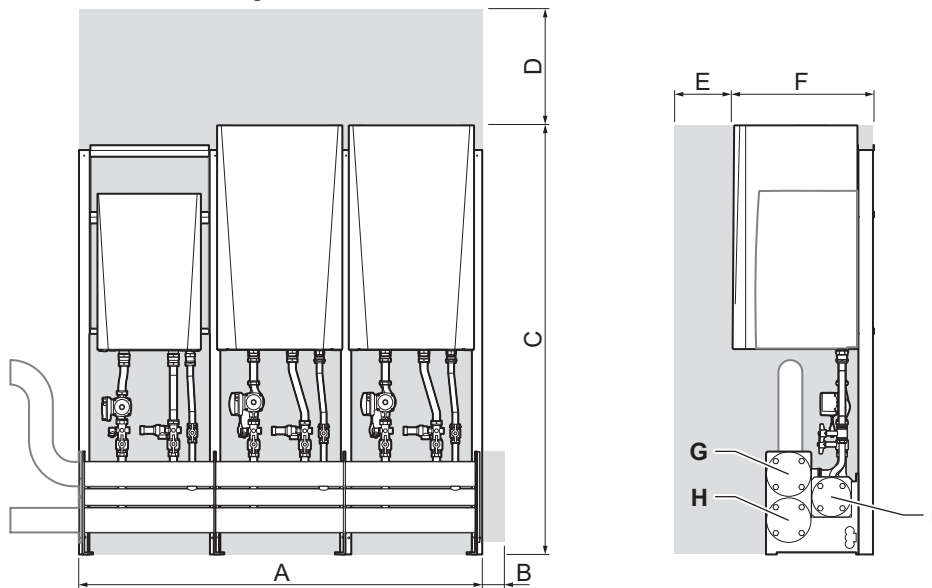

AD-30035036-01

Tab.12 Dimensions in mm with DN65 collector pipes

	Description	2 boilers	3 boilers	4 boilers	5 boilers	6 boilers	7 boilers	8 boilers
A	Total width	1110	1640	2170	2700	3230	3760	4290
B	Free space required for mounting the blanking flanges <sup>(1)</sup>	50	50	50	50	50	50	50
C	Total height	1576	1576	1576	1576	1576	1576	1576
D	Free space above the boilers (recommended)	500	500	500	500	500	500	500
E	Free space in front of the boilers (recommended)	1000	1000	1000	1000	1000	1000	1000
F	Total depth	575	575	575	575	575	575	575
G	Flow connection	DN65 PN6	DN65 PN6	DN65 PN6	DN65 PN6	DN65 PN6	DN65 PN6	DN65 PN6
H	Return connection	DN65 PN6	DN65 PN6	DN65 PN6	DN65 PN6	DN65 PN6	DN65 PN6	DN65 PN6
I	Gas connection	DN50 PN16	DN50 PN16	DN50 PN16	DN50 PN16	DN50 PN16	DN50 PN16	DN50 PN16

(1) When fitting a blanking flange with an expansion vessel connection, make sure there is enough space for fitting the vessel.

Tab.13 Dimensions in mm with DN100 collector pipes

	Description	2 boilers	3 boilers	4 boilers	5 boilers	6 boilers	7 boilers	8 boilers
A	Total width	1310	1940	2570	3200	3830	4460	5090
B	Free space required for mounting the blanking flanges <sup>(1)</sup>	55	55	55	55	55	55	55
C	Total height	2004	2004	2004	2004	2004	2004	2004
D	Free space above the boilers (recommended)	500	500	500	500	500	500	500
E	Free space in front of the boilers (recommended)	1000	1000	1000	1000	1000	1000	1000
F	Total depth	676	676	676	676	676	676	676
G	Flow connection	DN100 PN6	DN100 PN6	DN100 PN6	DN100 PN6	DN100 PN6	DN100 PN6	DN100 PN6
H	Return connection	DN100 PN6	DN100 PN6	DN100 PN6	DN100 PN6	DN100 PN6	DN100 PN6	DN100 PN6
I	Gas connection	DN65 PN16	DN65 PN16	DN65 PN16	DN65 PN16	DN65 PN16	DN65 PN16	DN65 PN16

(1) When fitting a blanking flange with an expansion vessel connection, make sure there is enough space for fitting the vessel.



Fig.44 Back-to-back configuration

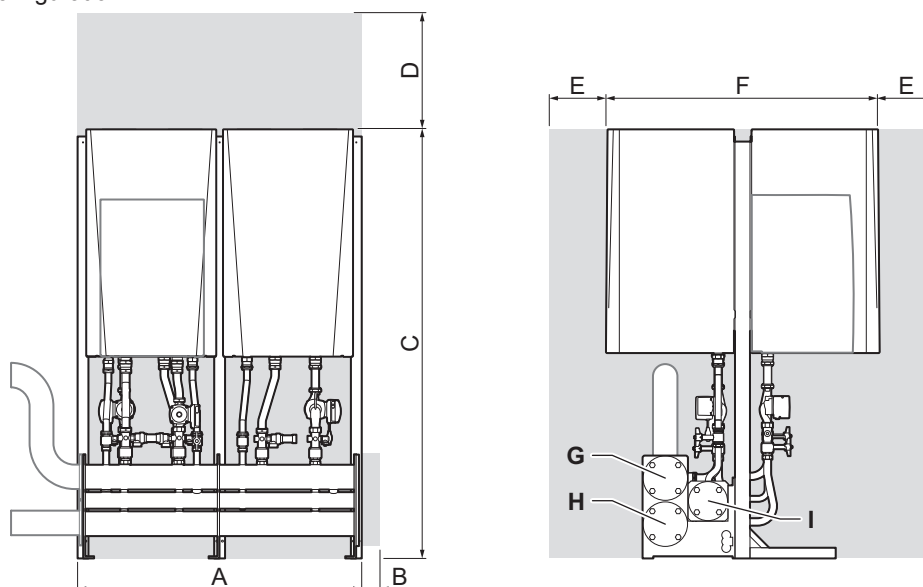

AD-3003037-01

Tab.14 Dimensions in mm with DN65 collector pipes

	Description	3-4 boilers	5-6 boilers	7-8 boilers
A	Total width	1110	1640	2170
B	Free space required for mounting the blanking flanges <sup>(1)</sup>	50	50	50
C	Total height	1576	1576	1576
D	Free space above the boilers (recommended)	500	500	500
E	Free space in front of the boilers (recommended)	1000	1000	1000
F	Total depth	1095	1095	1095
G	Flow connection	DN65 PN6	DN65 PN6	DN65 PN6
H	Return connection	DN65 PN6	DN65 PN6	DN65 PN6
I	Gas connection	DN50 PN16	DN50 PN16	DN50 PN16

(1) When fitting a blanking flange with an expansion vessel connection, make sure there is enough space for fitting the vessel.

Tab.15 Dimensions in mm with DN100 collector pipes

	Description	3 – 4 boilers	5 – 6 boilers	7 – 8 boilers
A	Total width	1310	1940	2570
B	Free space required for mounting the blanking flanges <sup>(1)</sup>	55	55	55
C	Total height	2004	2004	2004
D	Free space above the boilers (recommended)	500	500	500
E	Free space in front of the boilers (recommended)	1000	1000	1000
F	Total depth	1278	1278	1278
G	Flow connection	DN100 PN6	DN100 PN6	DN100 PN6
H	Return connection	DN100 PN6	DN100 PN6	DN100 PN6
I	Gas connection	DN65 PN16	DN65 PN16	DN65 PN16

(1) When fitting a blanking flange with an expansion vessel connection, make sure there is enough space for fitting the vessel.

## 7.2.2 Dimensions and connections - Low loss headers

The images in this chapter show DN65 low loss headers.

Fig.45 Low loss header dimensions - DN65 <350 kW

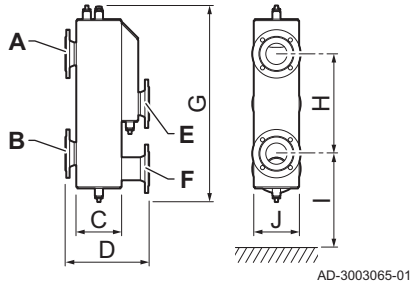

Tab.16 Low loss header dimensions - DN65 <350 kW

	Description	DN65 <350 kW	DN65 - DN100 <sup>(1)</sup>
A	flange size flow, system side	DN65 PN6	DN65 PN6
B	flange size return, system side	DN65 PN6	DN65 PN6
C	body depth	143	143
D	total depth	277	357
E	flange size flow, boiler side	DN65 PN6	DN100 PN6
F	flange size return, boiler side	DN65 PN6	DN100 PN6
G	total height	610	610
H	flange distance, system side	330	330
I	flange height, system side	200	200
J	total width	160	200

(1) Includes an adapter to connect the DN65 low loss header to an DN100 collector pipe set.

Fig.46 Low loss header dimensions - DN65 <350 kW - DN100

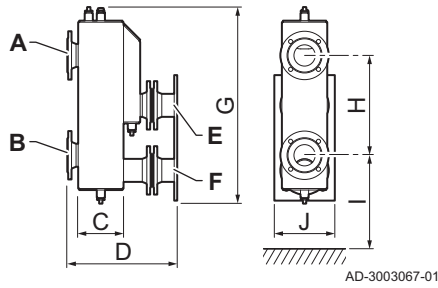
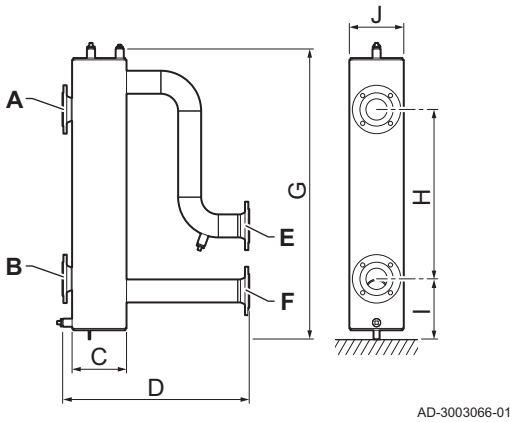

Fig.47 Low loss header dimensions



Tab.17 Low loss header dimensions

	Description	DN65	DN100
A	flange size flow, system side	DN65 PN6	DN100 PN6
B	flange size return, system side	DN65 PN6	DN100 PN6
C	body depth	180	250
D	total depth	617	631
E	flange size flow, boiler side	DN65 PN6	DN100 PN6
F	flange size return, boiler side	DN65 PN6	DN100 PN6
G	total height	960	960
H	flange distance, system side	560	560
I	flange height, system side	200	200
J	total width	180	250

Fig.48 Low loss header with dirt separator dimensions

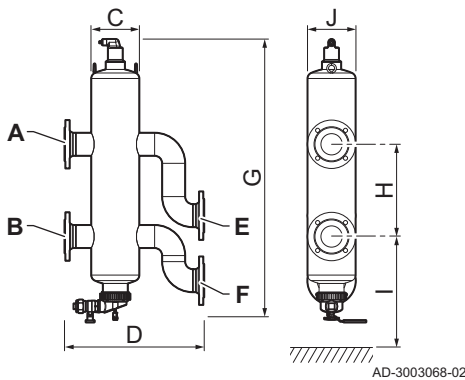

Tab.18 Low loss header with dirt separator dimensions

	Description	DN65	DN100
A	flange size flow, system side	DN65 PN6	DN100 PN6
B	flange size return, system side	DN65 PN6	DN100 PN6
C	body depth	ø159	ø219
D	total depth	462	744
E	flange size flow, boiler side	DN65 PN6	DN100 PN6
F	flange size return, boiler side	DN65 PN6	DN100 PN6
G	total height	905	1261
H	flange distance, system side	305	460
I	flange height, system side	306	414
J	total width	ø159	ø219

## 7.2.3 Dimensions and connections - Plate heat exchangers

Fig.49 Plate heat exchanger dimensions

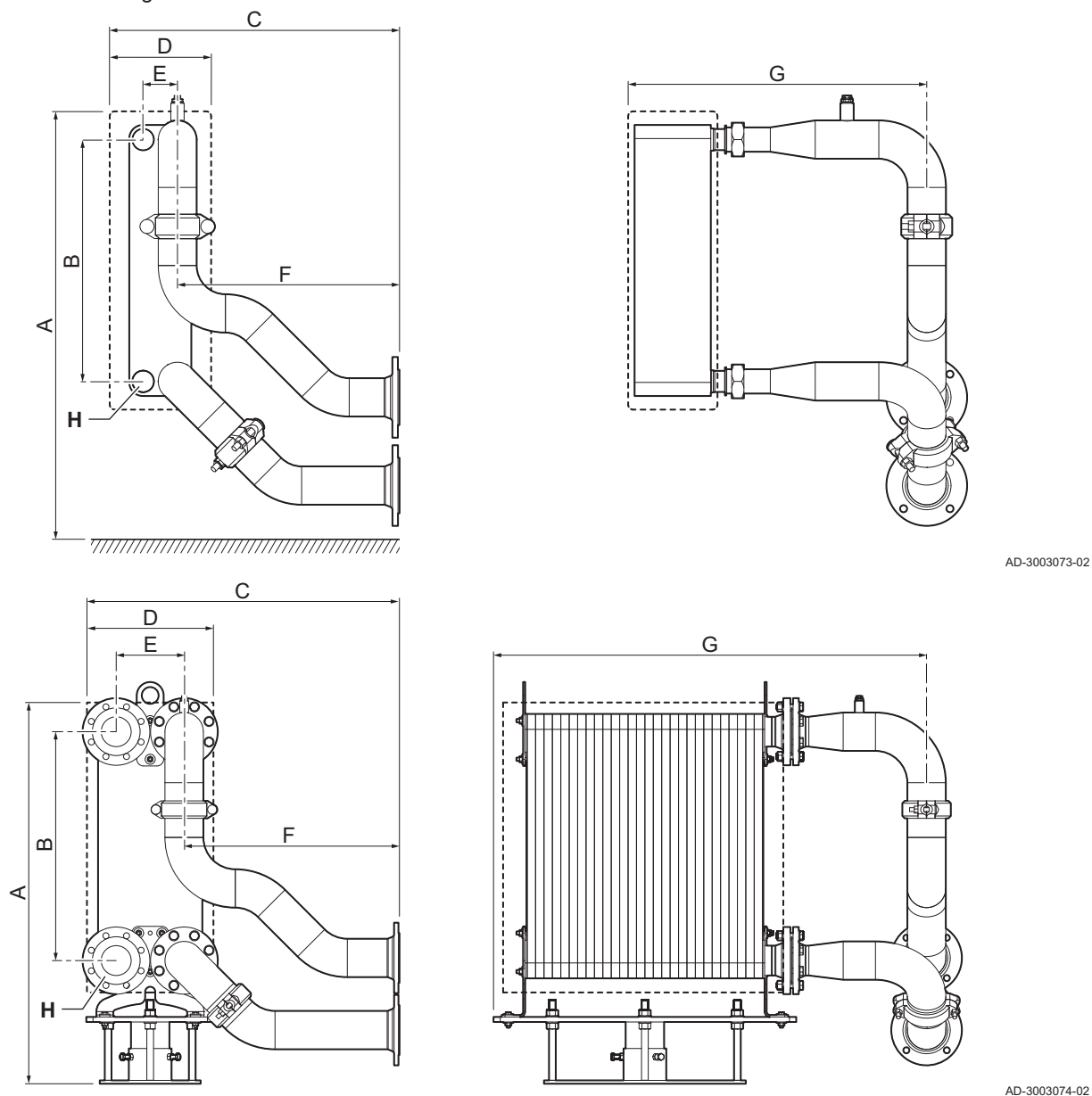

Tab.19 Plate heat exchanger dimensions in mm

Dimension	A	B	C	D	E	F	G	H
Description	total height	flange distance	total depth	depth	flange distance	connection depth	total width	connection size
RHB-60-60	752	480	617	201	68	400	604	1 1/4" outer thread
RHB-60-80	752	480	617	248	68	400	651	1 1/4" outer thread
RHB-60-100	752	480	617	295	68	400	698	1 1/4" outer thread
RHB-60-120	752	480	617	342	68	400	745	1 1/4" outer thread
RHB-60-140	752	480	617	389	68	400	792	1 1/4" outer thread
RHB-110-80	964	520	684	308	91	400	703	2" outer thread
RHB-110-100	964	520	684	360	91	400	755	2" outer thread
RHB-110-120	964	520	684	412	91	400	807	2" outer thread
RHB-110-140	977	520	698	526	91	400	890	2" outer thread

Dimension	A	B	C	D	E	F	G	H
Description	total height	flange distance	total depth	depth	flange distance	connection depth	total width	connection size
RHB-110-160	964	520	684	516	91	400	911	2" outer thread
RHB-110-180	964	520	684	568	91	400	963	2" outer thread
RMB-235-80	1140	682	1016	333	204	400	757	DN80
RMB-235-100	1140	682	1016	383	204	400	807	DN80
RMB-235-120	1140	682	1016	433	204	400	857	DN80
RMB-235-140	1140	682	1016	483	204	400	907	DN80
RMB-235-160	1140	682	1016	533	204	400	957	DN80
RMB-235-180	1140	682	1016	583	204	400	1007	DN80
RMB-235-200	1140	682	1016	633	204	400	1057	DN80
RMB-235-220	1140	682	1016	683	204	400	1107	DN80
RMB-235-240	1140	682	1016	733	204	400	1157	DN80
RMB-235-260	1140	682	1016	783	204	400	1207	DN80
RMB-235-280	1140	682	1016	833	204	400	1257	DN80





Original instructions - © Copyright

All technical and technological information contained in these technical instructions, as well as any drawings and technical descriptions supplied, remain our property and shall not be multiplied without our prior consent in writing. Subject to alterations.

**T** +44 (0)330 678 0140

**E** [technical@remeha.co.uk](mailto:technical@remeha.co.uk)

**W** [www.remeha.co.uk](http://www.remeha.co.uk)

**Remeha Commercial UK**

Brooks House  
Coventry Road  
Warwick  
CV34 4LL

CE

UK  
CA

