

BAXI

Baxi Unvented Direct & Indirect Hot Water Cylinders

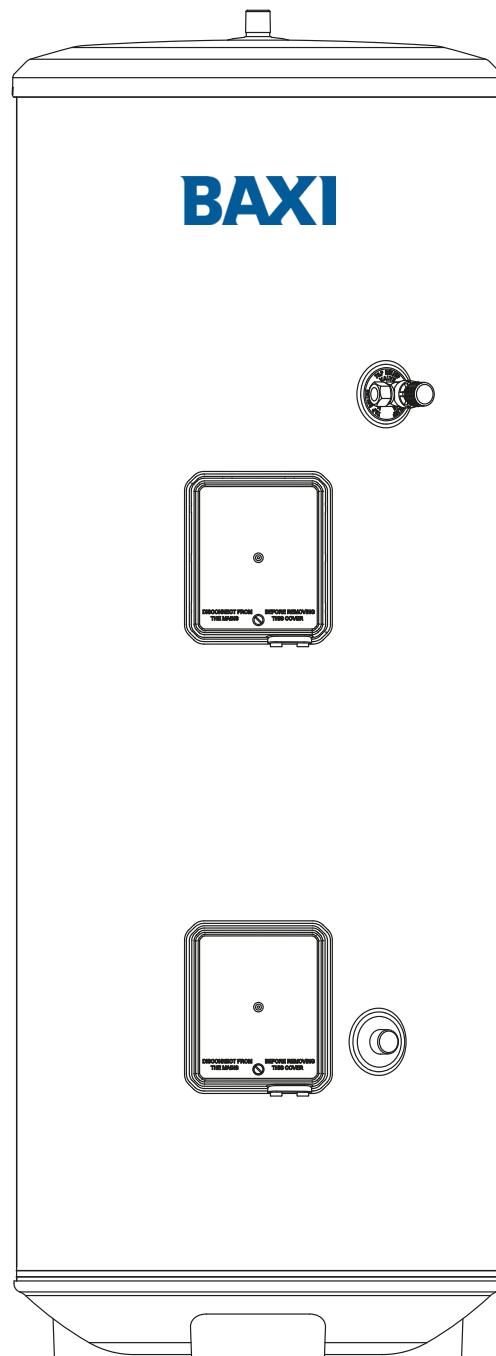

Important

Please read & understand all these instructions before commencing installation.
Please leave this manual with the customer for future reference

Contents

1. Introduction	3
1.1 General	3
1.2 Symbols used	3
1.3 Abbreviations	3
1.4 Liabilities	3
2. Safety	4
2.1 General safety warning	4
3. Technical specifications	5
4. Description of the product	10
4.1 General description	10
4.2 Operation principle	10
4.3 Main components	10
4.4 Standard delivery	10
4.5 Storage and Handling	10
5. Before installation	12
5.1 Installation regulations	12
5.2 Installation requirements	12
5.3 Choice of location	12
6. Installation	13
6.1 General	13
6.2 Water connections	13
6.3 Electrical connections	19
7. Commissioning	23
7.1 General	23
7.3 Commissioning procedure	23
8. Operation	24
8.1 General	24
9. Maintenance	25
9.1 General	25
9.2 Standard inspection & maintenance operations	25
10. Troubleshooting	27
10.1 Fault finding	27
11. Decommissioning	28
11.1 Decommissioning procedure	28
12. Spare parts	29
12.1 Spare parts list	29
Benchmark checklist	35
Commissioning & service records	36
Warranty	37



Benchmark™ places responsibilities on both manufacturers and installers. The purpose is to ensure that customers are provided with the correct equipment for their needs, that it is installed, commissioned and serviced in accordance with the manufacturer's instructions by competent persons and that it meets the requirements of the appropriate Building Regulations and relevant electrical qualifications. The Benchmark™ Checklist can be used to demonstrate compliance with Building Regulations and should be provided to the customer for future reference. Installers are required to carry out installation, commissioning and servicing work in accordance with the Benchmark™ Code of Practice which is available from the Heating and Hotwater Industry Council who manage and promote the Scheme. Visit www.centralheating.co.uk for more information. IMPORTANT NOTE TO USER: PLEASE REFER TO THE COMMISSIONING SECTION, PAGE 34 FOR IMPORTANT INFORMATION WITH RESPECT TO THE BENCHMARK SCHEME

1. Introduction

1.1 General

The following instructions are offered as a guide to the user and installer.

The installation must be carried out by a competent plumbing and electrical installer in accordance with the following:

- Building Regulation G3 (England and Wales),
- Technical Standard P3 (Scotland)
- Building Regulation P5 (Northern Ireland)
- Water Fitting Regulations (England and Wales)
- Water Byelaws (Scotland).

1.2 Symbols used

In these instructions, various risk levels are employed to draw the user's attention to particular information. In doing so we wish to safeguard the user, avoid hazards and guarantee the correct operation of the appliance.



DANGER

Risk of a dangerous situation causing serious physical injury.



WARNING

Risk of dangerous situation causing slight physical injury.



CAUTION

Risk of material damage.



Signals important information.

1.3 Abbreviations

- ▶ T&P - Temperature & Pressure relief valve
- ▶ PRV - Pressure reducing valve
- ▶ Prv - Pressure relief valve

1.4 Liabilities

Manufacturers liability

Our products are manufactured in compliance with the requirements of the various applicable European Directives.

This appliance complies with the requirements of the CE marking directive.

In the interest of UK customers, we are continuously endeavouring to make improvements in product quality. All the specifications stated in this document are therefore subject to change without notice.

Our liability as the manufacturer may not be invoked in the following cases:

- ▶ Failure to abide by the instructions on using the appliance.
- ▶ Faulty or insufficient maintenance of the appliance.
- ▶ Failure to abide by the instructions on installing the product.

Installer's liability

The installer is responsible for the installation and the commissioning of the appliance. The installer must respect the following instructions:

- ▶ Read and follow the instructions given in the manuals provided with the appliance.
- ▶ Carry out installation in compliance with the prevailing legislation and standards.
- ▶ Perform the initial start up and carry out any checks necessary.
- ▶ Complete the commissioning checklist.
- ▶ Explain the installation to the user.
- ▶ If maintenance is necessary, warn the user of the obligation to check the appliance and maintain it in good working order.
- ▶ Give all the instruction manuals to the user.

Users liability

To guarantee optimum operation of the appliance, the user must respect the following instructions:

- ▶ Read and follow the instructions given in the manuals provided with the appliance.
- ▶ Call on qualified professionals to carry out installation and initial start up.
- ▶ Get your installer to explain your installation to you.
- ▶ Have your required checks and services done.
- ▶ Keep the instruction manuals in good condition and close to the appliance.

 This appliance can be used by children aged from 3 years and above and persons with reduced physical sensory or mental capabilities or lack of experience and knowledge if they have been given supervision or instruction concerning use of the appliance in a safe way and understand the hazards involved. Children shall not play with the appliance. Cleaning and user maintenance shall not be made by children without supervision.

Children must be supervised to ensure they do not play with the appliance.

Children aged from 3 to 8 years are only allowed to operate the tap connected to the water heater



- Water may drip from the discharge pipe of the pressure-relief device and this pipe must be left open to the atmosphere; (see page 18 for more details)

-the pressure-relief device is to be operated regularly to remove lime deposits and to verify that it is not blocked; (see page 25 for more details)

- How hot water can be drained. (see page 25 for more details)

- The type or characteristics of the pressure-relief device and how to connect it; (see Fig. 3 page 9)

- A discharge pipe connected to the pressure-relief device is to be installed in a continuously downward direction and in frost free environment; (see Fig. 3, page 9 for details)

Details on how to set the temperature controls for both immersion heaters and boiler controls can be found in section 6. Installation, page 20.

2. Safety

2.1 General safety warning



WARNING

- ▶ Only competent persons having received adequate training are permitted to work on the appliance and the installation.
- ▶ Where the inlet supply to the Pressure Reducing Valve is routed through a heated space and is fitted with a check valve or other fitting that would prevent backflow, high pressures can be experienced in the inlet pipe due to warming that can cause damage to the PRV or other fittings on the inlet supply. In these circumstances, the installation of a means to accommodate expansion and thus limit the pressure rise in the inlet pipe is recommended
- ▶ Do not tamper with any of the safety valves or controls supplied with the cylinder.
- ▶ Before any work, switch off the mains supply to the appliance.
- ▶ Do not switch on if there is a possibility that the water in the cylinder is frozen.

- ▶ The HWA Charter Statement requires that all members adhere to the following:
 - ▶ To supply fit for purpose products clearly and honestly described.
 - ▶ To supply products that meet, or exceed appropriate standards and building and water regulations.
 - ▶ To provide pre and post sales technical support.
 - ▶ To provide clear and concise warranty details to Customers.



DANGER

This cylinder is unvented and as such becomes pressurised when in operation. The combination of pressurisation and hot water could lead to serious physical injury if the safety instructions in this manual are not adhered to.



WARNING

When handling the unit, take appropriate precautions for the weight of the unit. Weights can be found in section 3 Technical specifications, Tables 1&2, pages 5&6.



CAUTION

Annual maintenance is recommended by a competent person.



CAUTION

Do not operate immersion heaters until the cylinder has been filled with water.



WARNING TO USER

- ▶ If water discharges from the temperature/pressure relief valve on the cylinder shut down the boiler/immersion heaters. Do not turn off any water supply. Contact a competent Installer for unvented water heaters to check the system.
- ▶ Do not remove or adjust any component or part of this unvented water heater ; contact installer
- ▶ DO NOT bypass the thermal cut-out(s) in any circumstances.

3. Technical specifications

Table 1: Technical data - Indirect Cylinders

Technical parameters in accordance with European Commission regulations 814/2013 and 812/2013

	125i	145i	170i	210i	250i	300i	
Max No. of elements allowed/fitted	3	3	3	3	3	3	
Immersion heat up times at 50° temp. rise (Btm immersion, 3kW)	159	182	212	230	276	330	
Coil surface area (m ²)	0.51						
Coil heat up times	15l/min	30.6	34.9	40.3	44.8	53.3	65.1
	30l/min	26.0	28.4	34.1	37.0	43.5	47.9
	45l/min	24.0	26.1	30.0	33.1	40.0	47.2
Coil rating (kW) ²	15l/min	11.6	11.8	12.5	12.8	13.0	11.8
	30l/min	13.4	12.3	12.9	13.2	15.2	14.3
	45l/min	15.4	12.4	13.8	14.4	15.5	15.7
Pressure drop through coil	15l/min	0.006 MPa (0.06 Bar)					
	30l/min	0.022 MPa (0.22 Bar)					
	45l/min	0.048 MPa (0.48 Bar)					
Heat loss (kWh/24hrs)	1.28	1.39	1.60	1.82	1.84	2.18	
Weight empty (kg)	34	38	41	41	51	54	
Weight full (kg) ¹	170	194	223	238	288	337	
Volume (Litres) ¹	136	156	182	197	237	283	
Mixed water delivery to 40°C ¹	176	197	233	258	320	386	
Max mains pressure	1.6 MPa (16 Bar)						
Max design pressure	0.8 MPa (8 Bar)						
Operating pressure/PRV set pressure	0.3 MPa (3 Bar)						
Max primary pressure ³	1.0 MPa (10 Bar)						
Expansion relief valve setting	0.8 MPa (8 Bar)						
T&P valve setting	90°C +/- 5°C/1.0 MPa (10 Bar)						
T&P Part number	95605209						
Immersion heater electrical rating	3.0 kW@240V/2.8kW@230V ~						

ErP Data

Model(s)	125i	140i	170i	210i	250	300i
Energy efficiency class	C	C	C	C	C	C
Standing loss W	53.3	57.9	66.7	75.8	76.7	93.3
Storage volume V in Litres	136	156	182	197	237	283

Notes:

1: at 3 bar water inlet pressure the cylinder is filled with the maximum amount of water. Controlled by a 3 Bar P.R.V.

2: at 80°C - +/- 2°C

3: Although the primary coil pressure rating is 1.0MPa (10bar) the 2 port zone valve and coil compression nuts supplied with the cylinder are only rated at 0.86MPa (8.6 bar). If the cylinder is to be plumbed into a system delivering 1.0MPa (10 bar) a suitable 2 port zone valve and the coil compression nuts will have to be sourced.

4: Tested to EN 12897:2016

Table 2: Technical data - Direct Cylinders

Technical parameters in accordance with European Commission regulations 814/2013 and 812/2013

	125DD	145DD	170DD	210DD	250DD	300DD
Max direct kW rating	6	6	6	6	6	6
Immersion heat up times (Btm immersion, 3kW)	139	175	193	205	267	309
Immersion heat up times (Top immersion, 3 kW)	65	83	87	89	96	92
Immersion heat up times (Both immersions, 6kW)	62	79	88	90	98	93
Heat loss (kWh/24hrs)	1.29	1.43	1.66	1.67	1.96	2.25
Mixed water delivery to 40°C ¹	168	188	218	238	281	354
Weight empty (kg)	25	31	34	38	46	56
Weight full (kg) ¹	165	183	216	237	282	338
Volume (Litres) ¹	140	152	182	199	236	283
Max mains pressure	1.6MPa (16 Bar)					
Max design pressure	0.8 MPa (8 Bar)					
Operating pressure/PRV set pressure	0.3 MPa (3 Bar)					
Expansion relief valve setting	0.8 MPa (8 Bar)					
T&P valve setting	90°C +/- 5°C/1.0 MPa (10 Bar)					
T&P Part number	95605209					
Immersion heater electrical rating	3.0 kW@240V/2.8kW@230V ~					

ErP Data						
Suppliers model identifier	125DD	145DD	170DD	210DD	250DD	300DD
Storage volume V in Litres	140	152	182	199	236	282
Mixed water at 40°C V40 in Litres	155	180	217	16	273	359
The declared load profile	M	L	L	L	XL	XL
The water heating energy efficiency class of the model	C	C	C	C	C	C
The water heating efficiency in %	37	38	38	38	38	38
The annual electricity consumption in kWh	1397	2729	2697	2666	4379	4376
Daily fuel consumption Q in kWh	6.52	12.66	12.47	12.29	20.20	20.20
The thermostat temperature settings of the water heater as placed on the market by the supplier.	60°C					
Specific precautions that shall be taken when the water heater is assembled, installed or maintained and disposed of at end of life.	See pages 3 to 32					

Notes:

- 1: at 3 bar water inlet pressure the cylinder is filled with the maximum amount of water. Controlled by a 3 Bar P.R.V.
- 2: Tested to the following standards:
 - Indirect - EN 12897:2016
 - Direct - EN 15332:2019
- 3: Energy efficiency tested to EN50440

General information:

Outer casing

White pre-coated corrosion protected steel body shell. Polypropylene top and base mouldings. ABS electrical controls housings and enclosures.

Water container

Duplex stainless steel. 100% pressure tested to 1.6MPa (16 bar).

Connections

Pipe connections accept 22mm outside diameter pipe (compression nuts and olives supplied). Thread rate is 3/4" BSP parallel to accept standard 3/4" BSP female fittings if required.

Thermal insulation

CFC/HCFC free fire retardant expanded polyurethane foam with zero ozone depletion potential. It has a Global Warming Potential (GWP) of 3.1.

Safety Features

Direct models: Manually re-settable thermal cut-out on each immersion heater. Factory fitted combined T&P and Expansion Relief Valve. See 6.3 Electrical connections, page 19

Indirect models: Manually re-settable thermal cut-out on immersion heater. Manually re-settable thermal cut-out for primary heating - must be wired in conjunction with 2 port motorised valve supplied. Factory fitted T&P/Expansion Relief Valve. See 6.3 Electrical connections, page 20

Figure 1: General dimensions - Direct models

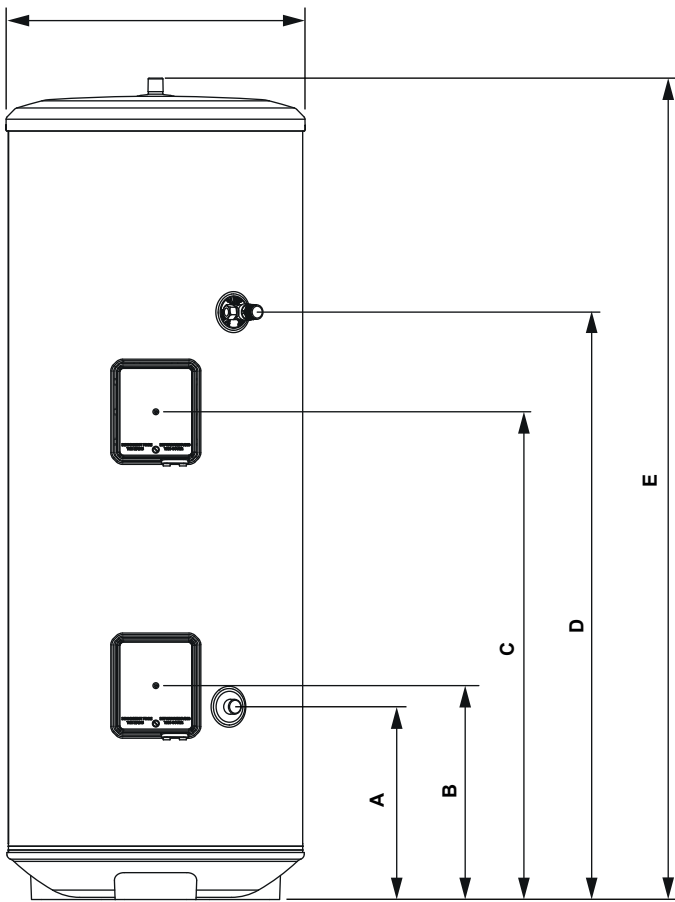

Table 3: Dimensions Direct Cylinders

Size	DIMENSIONS (mm)				
	A	B	C	D	E
125	356	394	668	782	1131
145	356	394	680	883	1258
170	356	394	804	1008	1414
210	356	394	900	1084	1516
250	356	395	1110	1309	1767
300	355	396	1413	1574	2081

Figure 2: General dimensions - Indirect models

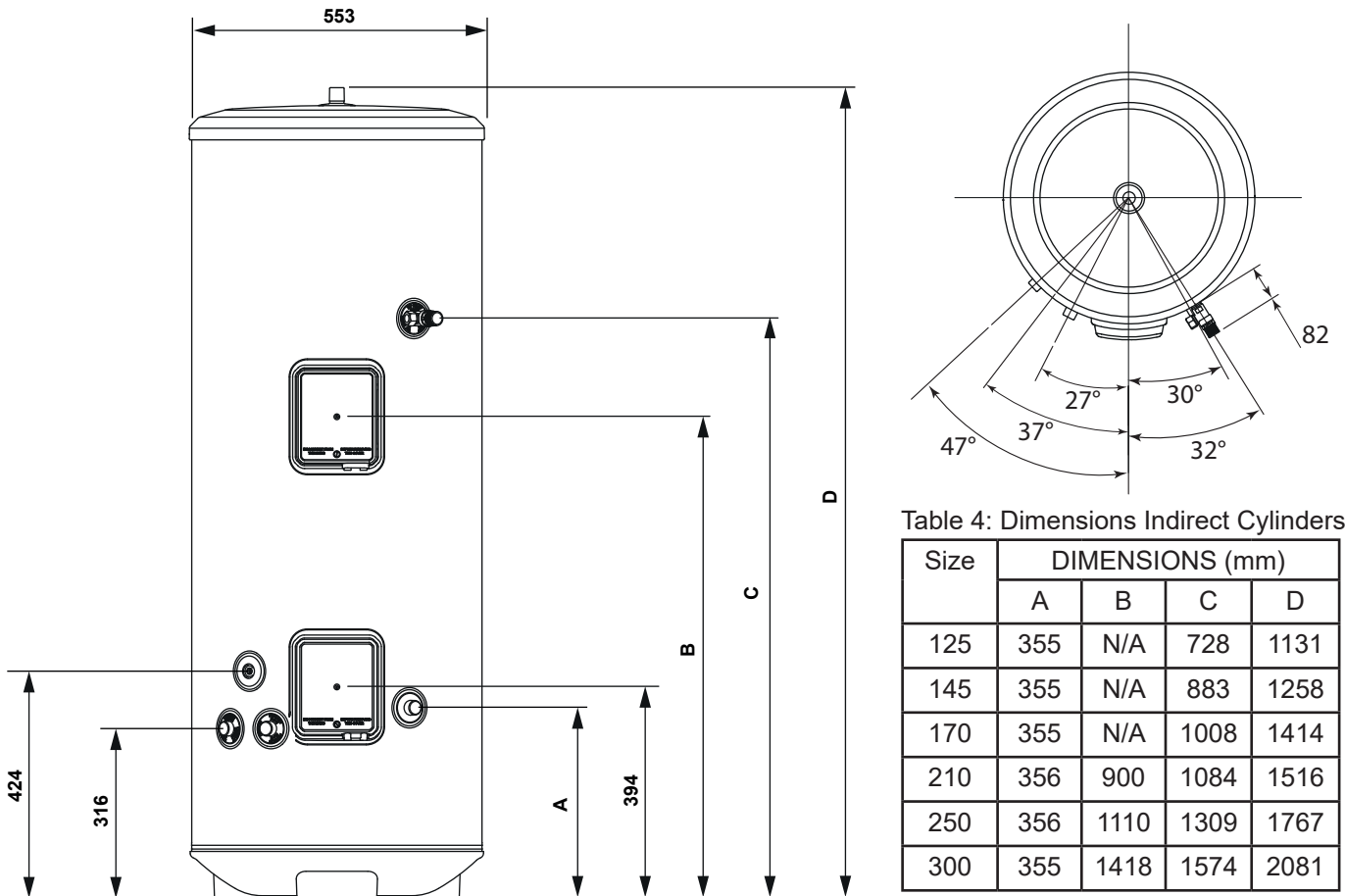
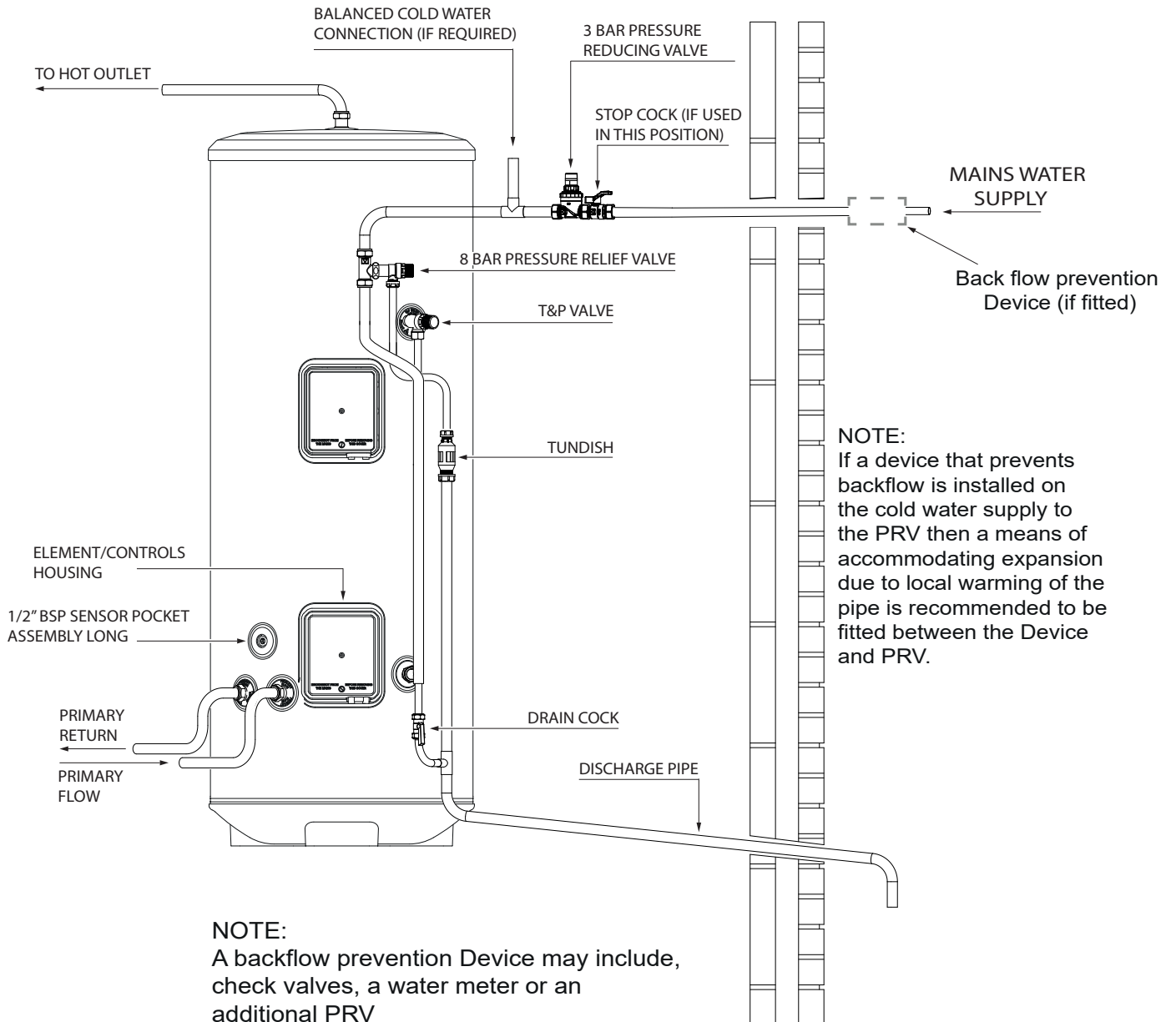

Table 4: Dimensions Indirect Cylinders

Size	DIMENSIONS (mm)			
	A	B	C	D
125	355	N/A	728	1131
145	355	N/A	883	1258
170	355	N/A	1008	1414
210	356	900	1084	1516
250	356	1110	1309	1767
300	355	1418	1574	2081

Figure 3: Schematic installation details



4. Description of the product

4.1 General description

This appliance is a purpose designed unvented water heater. The unit has a stainless steel inner vessel, which ensures an excellent standard of corrosion resistance. The outer casing is a combination of resilient thermoplastic mouldings and pre-painted corrosion proofed steel. All products are insulated with CFC free polyurethane foam to give good heat loss protection.

The appliance is supplied complete with all the necessary safety and control devices needed to allow connection to the cold water mains. All these components are preset and should not be tampered with.

4.2 Operation principle

The unvented cylinder is used to heat and store hot water for use in domestic applications.

Depending on the model the water can be heated directly using factory fitted Immersion heater(s) or indirectly through a coil in the unit using an indirect heat source.

To provide pressure to the tap or shower an unvented water heater uses the incoming mains water pressure. To do this the water heater is sealed and not vented. However, when the volume of water is heated it expands and without any room for expansion could cause the water heater to rupture and fail. The water heater requires no separate expansion vessel to accommodate this expansion as it incorporates an internal air gap.

4.3 Main components

See Fig. 3, page 9

4.4 Standard delivery

The delivery includes:

- ▶ Cylinder incorporating factory fitted immersion heater(s) and thermal controls and factory fitted temperature and pressure relief valve
- ▶ Instructions (inc benchmark commissioning checklist & service record)
- ▶ Warranty card
- ▶ Cold water control pack
- ▶ Pressure reducing valve
- ▶ Isolation valve
- ▶ Tundish
- ▶ Drain valve
- ▶ Nut and olive kit
- ▶ Immersion spanner
- ▶ 2 port zone valve (indirect only)
- ▶ Wiring centre (indirect only)

Check all components are supplied in the pack and advise your supplier if any are missing.

4.5 Storage and Handling

If the unit is to be stored before installation it must be placed upright on a secure, level surface and be in a dry, frost free environment. The support surface must be capable of supporting the packaged weight of the unit, the packaged weights are displayed on the carton label.

Please take care when handling a packaged cylinder. The units are heavy and must only be moved manually using safe working practices. The package weights of each unit are displayed on the carton label.

Take note of the unit weights when deciding on a safe lifting method. DO NOT use the factory fitted T&P/Expansion Relief Valve to lift or manoeuvre the unit.



CAUTION

This unit should be kept upright if transported by vehicle, if not it could damage the internal heating coil.

Figure 4: Typical system installation schematic (not to scale)

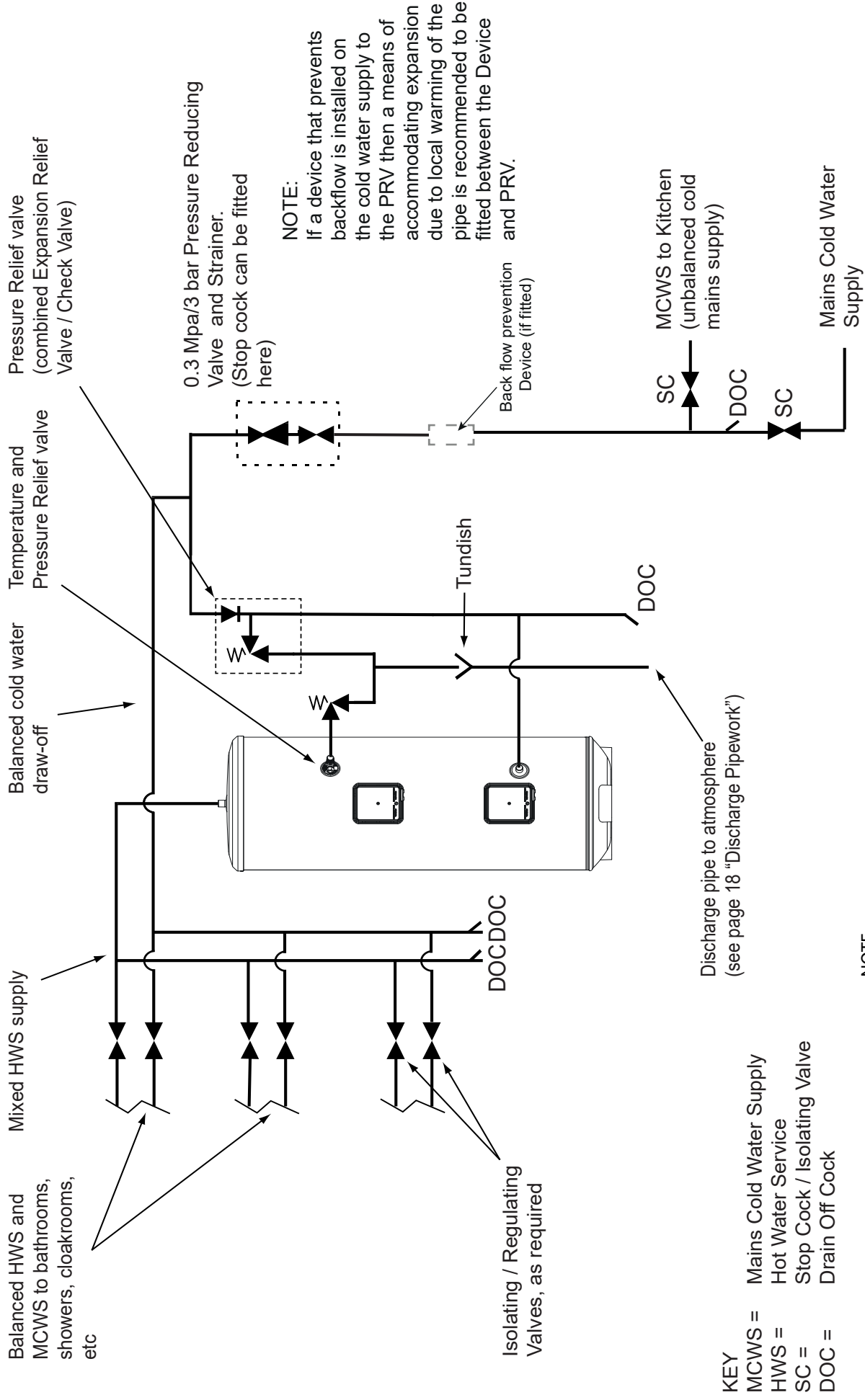

NOTE:
A backflow prevention Device may include check valves, a water meter or an additional PRV

5. Before installation

5.1 Installation regulations



WARNING

Installation of the appliance must be carried out by a qualified engineer in accordance with prevailing and national regulations as listed below.

- ▶ Building Regulations G3
- ▶ The Building Standards (Scotland)
- ▶ The Building Regulations (Northern Ireland)
- ▶ I.E.E Electrical Regs
- ▶ UK Water Regulations

5.2 Installation requirements

Water supply

In an unvented system the pressure and flowrate is directly related to the incoming water supply. For this reason it is recommended that the maximum water demand is assessed and the water supply checked to ensure this demand can be satisfactorily met.

- ▶ We suggest the minimum supply requirements should be 0.15MPa (1.5 bar) dynamic working pressure and 20 litres per minute flow rate. However, at these values outlet flow rates may be poor if several outlets are used simultaneously.
- ▶ A 22mm cold water supply is recommended, however, if a smaller supply exists, which provides sufficient flow, this may be used (although more flow noise may be experienced).
- ▶ The higher the available pressure and flow rate the better the system performance.
- ▶ See Tables 1&2 on pages 5&6 for cylinder operating pressures. This is controlled by the Pressure Reducing valve (PRV).

Outlet/terminal fittings (taps, etc.)

- ▶ The appliance can be used with most types of terminal fittings.
- ▶ Outlets situated higher than the appliance will give outlet pressures lower than that at the appliance, a 10m height difference will result in a 1 bar pressure reduction at the outlet.
- ▶ All fittings, pipework and connections must have a rated pressure of at least 8 bar at 80°C.

Limitations

The appliance should not be used in association with any of the following:

- ▶ Solid fuel boilers or any other boiler in which the energy input is not under effective thermostatic control, unless additional and appropriate safety measures are installed.

- ▶ Ascending spray type bidets or any other class 1 back syphonage risk requiring that a type A air gap be employed.
- ▶ Steam heating plants unless additional and appropriate safety devices are installed.
- ▶ Situations where maintenance is likely to be neglected or safety devices tampered with.
- ▶ Water supplies that have either inadequate pressure or where the supply may be intermittent.
- ▶ Situations where it is not possible to safely pipe away any discharge from the safety valves.
- ▶ In areas where the water consistently contains a high proportion of solids, e.g. suspended matter that could block the strainer, unless adequate filtration can be ensured.
- ▶ In areas where the water supply contains chloride levels that exceed 250mg/l.

5.3 Choice of location

The appliance must be vertically floor mounted. Although location is not critical, the following points should be considered:

- ▶ The appliance should be sited to ensure minimum dead leg distances, particularly to the point of most frequent use.
- ▶ Avoid siting where extreme cold temperatures will be experienced. All exposed pipe work should be insulated.
- ▶ The discharge pipework from the safety valves must have minimum fall of 1:200 from the appliance and terminate in a safe and visible position as per G3 requirements.
- ▶ Access to associated controls and immersion heaters must be available for the servicing and maintenance of the system. Where these controls are installed facing a wall a minimum distance of 250mm must be left (see Fig. 5, below).
- ▶ Note of the overall height of the appliance in relation to the ceiling height and ensure that access and space is available for the blending valve, piping and connections to the outlet.
- ▶ Ensure that the floor area for the appliance is level and capable of permanently supporting the weight when full of water (see Tables 1&2, pages 5&6) for weights.
- ▶ The tundish should be installed away from electrical components.

Figure 5: Location of the appliance

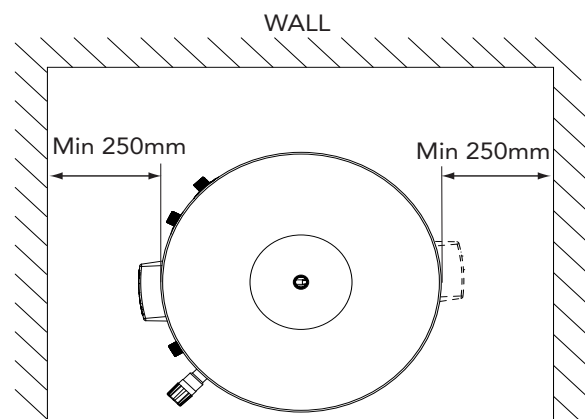

6. Installation

6.1 General

After reading the previous sections in this booklet and choosing a suitable location for the appliance please install, paying attention to the following water, electrical and commissioning sections.

Boiler selection (Indirect units only)

- ▶ The boiler should have a control thermostat and non self-resetting thermal cut-out and be compatible with unvented storage water heaters.
- ▶ Where use of a boiler without a thermal cut-out is unavoidable a "low head" open vented primary circuit should be used. The feed and expansion cistern head above the cylinder should not exceed 2.5m.
- ▶ Can be a sealed system or open vented type - maximum primary pressure 10 bar but must be fully pumped.
- ▶ The boiler cannot be vented through the cylinder.

- ▶ The Cold Water Inlet Control kit supplied incorporates a full flow isolating valve which will enable the appliance to be isolated from the mains supply for maintenance or servicing.
- ▶ The location of the unit should allow access to the T&P Relief valve to allow re-charging of the internal air gap when necessary.
- ▶ The draining tap supplied should be installed in the cold water supply to the cylinder between the expansion valve and the heater at as low a level as possible.
- ▶ It is recommended that the outlet point of the drain pipework be at least 1 metre below the level of the base of the appliance (this can be achieved by attaching a hose to the drain tap outlet spigot).
- ▶ Hot water distribution pipework should be 22mm pipe with short runs of 15mm pipe to terminal fittings such as sinks and basins. Pipe sizes may vary due to system design.

6.2 Water connections



WARNING

- ▶ The cold water controls **MUST** be fitted on the mains water supply to the appliance.
- ▶ **PRV WARNING: IF THERE IS AN UPSTREAM CHECK VALVE OR FITTING WHICH MAY PREVENT BACKFLOW THEN HIGH PRESSURES CAN BE EXPERIENCED DUE TO AMBIENT TEMPERATURES WHICH CAN CAUSE DAMAGE TO THE VALVES AND FITTINGS**
- ▶ No control or safety valves should be tampered with or used for any other purpose.
- ▶ The discharge pipe should not be blocked or used for any other purpose.
- ▶ The tundish should not be located adjacent to any electrical components.

Refer to the installation schematic (Fig. 3, page 9) for details on the pipework layout. Specific details for the discharge pipework layout is also provided in Fig. 9 on page 18.

- ▶ All connections accept 22mm outside diameter pipe (compression nuts and olives supplied). The thread rate is 3/4" BSP Male parallel to accept standard 3/4" BSP Female fittings if required.

Cold water control pack

IMPORTANT INSTALLATION NOTE:

WHERE THE INLET SUPPLY TO THE PRESSURE REDUCING VALVE (PRV) IS ROUTED THROUGH A HEATED SPACE AND IS FITTED WITH A CHECK VALVE OR OTHER FITTING THAT WOULD PREVENT BACK FLOW, HIGH PRESSURES CAN BE EXPERIENCED IN THE INLET PIPE DUE TO WARMING THAT CAN CAUSE DAMAGE TO THE PRV OR OTHER FITTINGS ON THE INLET SUPPLY.

IN THESE CIRCUMSTANCES, THE INSTALLATION OF A MEANS TO ACCOMMODATE EXPANSION AND THUS LIMIT THE PRESSURE RISE IN THE INLET PIPE IS RECOMMENDED.



CAUTION

- ▶ Flush supply pipework before connection to remove all flux and debris prior to fitting the inlet controls. Failure to do this may result in irreparable damage to the controls and will invalidate any warranty.

Figure 6: Pressure Reducing Valve

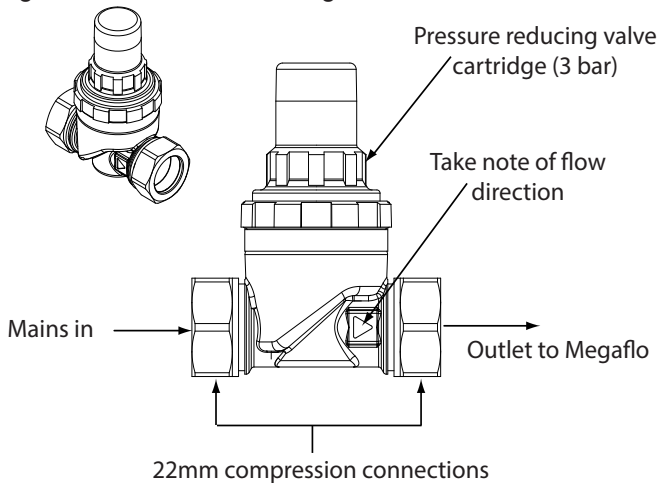

- ▶ The cold water control pack can be connected anywhere on the cold water cylinder supply.
- ▶ The Control pack incorporates the pressure reducing valve and isolation valve.
- ▶ The pressure setting is set to 0.3MPa/3.0 bar.
- ▶ The valve can be fitted in any orientation to suit the installation as long as the valve is installed with the direction of flow arrows pointing in the correct direction.
- ▶ The expansion relief valve should be installed with the discharge pipework in either the horizontal position or facing downwards.
- ▶ No other valves should be placed between the cold pressure reducing valve and the appliance.

Primary circuit control

- ▶ The 2 port motorised valve supplied with the appliance **MUST** be fitted on the primary flow to the appliance heat exchanger and wired such that in the event of the appliance overheating it will close the primary circuit.
- ▶ Primary circulation to the appliance heat exchanger must be pumped; gravity flow to the appliance heat exchanger **WILL NOT WORK**.
- ▶ It is recommended that an air bleed or automatic air vent is incorporated in the primary return pipe work close to the unit.
- ▶ Boiler flow temperature should be set to 80°C (peak temperature not to exceed 88°C).

Figure 7: Cold water controls

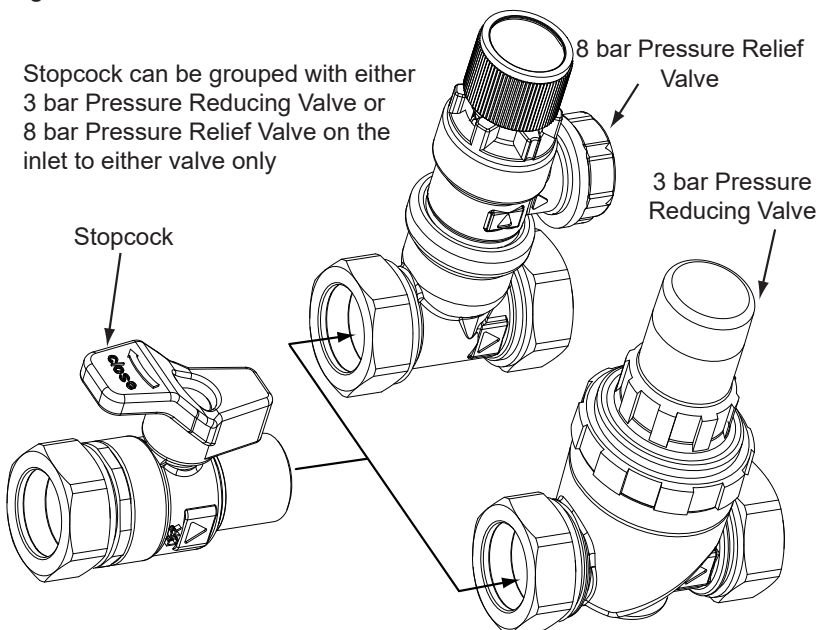

Secondary circulation

If secondary circulation is required it is recommended that it be connected to the cylinder as shown (see Fig. 8).

- ▶ The secondary return pipe should be in 15mm pipe and incorporate a check valve to prevent backflow.
- ▶ A suitable WRAS approved circulation pump will be required.
- ▶ On large systems, due to the increase in system water content, it may be necessary to fit an additional expansion vessel to the secondary circuit. This should be done if the capacity of the secondary circuit exceeds 10 litres. It is recommended that a swept Tee is fitted to direct water flow to the cylinder to improve performance.

Pipe capacity (copper):

15mm O.D. = 0.13 l/m (10 litres = 77m)

22mm O.D. = 0.38 l/m (10 litres = 26m)

28mm O.D. = 0.55 l/m (10 litres = 18m)

Note: Plastic pipe capacities may be reduced due to

Figure 8: Secondary circulation schematic (direct)

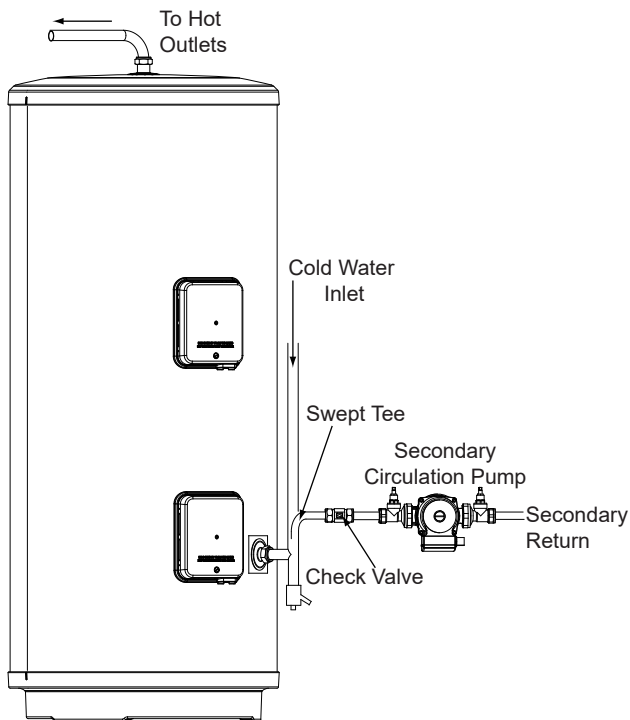

thicker wall sections.

i In direct electric installations where a secondary circulation is required particular attention should be paid by the installer to maintain the returning water temperature (guidelines state that a minimum of 55°C return temperature is advisable). Factors such as, but not limited to, secondary circulation flow rates, minimising heat loss of all secondary circuit pipework and timed operation during periods of high demand are critical to the correct operation and longevity of the heating element(s) and thermostats.

! Secondary circulation is not recommended for direct electric units using off-peak tariffs where the secondary circulation is not controlled in conjunction with the heat source as performance can be affected.

Discharge

It is a requirement of Building Regulation G3 that any discharge from an unvented system is conveyed to where it is visible, but will not cause danger to persons in or about the building. The tundish and discharge pipes should be fitted in accordance with the requirements and guidance notes of Building Regulation G3. The G3 Requirements and Guidance section 3.50 - 3.63 are reproduced in the following sections of this manual. For discharge pipe arrangements not covered by G3 Guidance advice should be sought from your local Building Control Officer. Any discharge pipe connected to the pressure relief devices (expansion valve and temperature/pressure relief valve) must be installed in a continuously downward direction and in a frost free environment.

Water may drip from the discharge pipe of the pressure relief device. This pipe must be left open to the atmosphere. The pressure relief device is to be operated regularly to remove lime deposits and to verify that it is not blocked.

G3 REQUIREMENT

“...there shall be precautions...to ensure that the hot water discharged from safety devices is safely conveyed to where it is visible but will not cause danger to persons in or about the building.”

The following extract is taken from the latest G3 Regulations

Discharge pipes from safety devices

Discharge pipe D1

3.50 Safety devices such as temperature relief valves or combined temperature and pressure relief valves (see paragraphs 3.13 or 3.18) should discharge either directly or by way of a manifold via a short length of metal pipe (D1) to a tundish.

3.51 The diameter of discharge pipe (D1) should be not less than the nominal outlet size of the safety device, e.g. temperature relief valve.

3.52 Where a manifold is used it should be sized to accept and discharge the total discharge from the discharge pipes connected to it.

3.53 Where valves other than a temperature and pressure relief valve from a single unvented hot water system discharge by way of the same manifold that is used by the safety devices, the manifold should be factory fitted as part of the hot water storage system unit or package.

Tundish

3.54 The tundish should be vertical, located in the same space as the unvented hot water storage system and be fitted as close as possible to, and lower than, the safety device, with no more than 600mm of pipe

between the valve outlet and the tundish (see Fig. 9, page 18).

Note: To comply with the Water Supply (Water Fittings) Regulations, the tundish should incorporate a suitable air gap.

3.55 Any discharge should be visible at the tundish. In addition, where discharges from safety devices may not be apparent, e.g. in dwellings occupied by people with impaired vision or mobility, consideration should be given to the installation of a suitable safety device to warn when discharge takes place, e.g. electronically operated.

Discharge pipe D2

3.56 The discharge pipe (D2) from the tundish should:
(a) have a vertical section of pipe at least 300mm long below the tundish before any elbows or bends in the pipework (see Fig. 9); and
(b) be installed with a continuous fall thereafter of at least 1 in 200.

3.57 The discharge pipe (D2) should be made of:

- (a) metal; or*
- (b) other material that has been demonstrated to be capable of safely withstanding temperatures of the water discharged and is clearly and permanently marked to identify as specified in the relevant part of BS 7291- 1:2006 Thermostatic pipes and fittings for hot and cold water for domestic purposes and heating installations in buildings.General requirements).*

3.58 The discharge pipe (D2) should be at least one pipe size larger than the nominal outlet size of the safety device unless its total equivalent hydraulic resistance exceeds that of a straight pipe 9m long, i.e. for discharge pipes between 9m and 18m the equivalent resistance length should be at least two sizes larger than the nominal outlet size of the safety device; between 18 and 27m at least 3 sizes larger, and so on; bends must be taken into account in calculating the flow resistance. See Fig. 9, Table 5 and the worked example.

Note: An alternative approach for sizing discharge pipes would be to follow Annex D, section D.2 of BS 6700:2006 + A1:2009

Specification for design, installation, testing and maintenance of services supplying water for domestic use within buildings and their curtilages.

3.59 Where a single common discharge pipe serves more than one system, it should be at least one pipe size larger than the largest individual discharge pipe (D2) to be connected.

3.60 The discharge pipe should not be connected to a soil discharge stack unless it can be demonstrated that the soil discharge stack is capable of safely withstanding temperatures of the water discharged, in which case, it should:

- (a) contain a mechanical seal, not incorporating a water trap, which allows water into the branch pipe without allowing foul air from the drain to be ventilated through the tundish;
- (b) be a separate branch pipe with no sanitary appliances connected to it;
- (c) if plastic pipes are used as branch pipes carrying discharge from a safety device, they should be either polybutalene (PB) or cross-linked polyethylene (PE-X) complying with national standards such as Class S of BS 7291-2:2006 or Class S of BS 7291-3:2006 respectively; and
- (d) be continuously marked with a warning that no sanitary appliances should be connected to the pipe.

Note:

1. Plastic pipes should be joined and assembled with fittings appropriate to the circumstances in which they are used as set out in BS EN ISO 1043-1:2002 Plastics. Symbols and abbreviated terms. Basic polymers and their special characteristics.
2. Where pipes cannot be connected to the stack it may be possible to route a dedicated pipe alongside or in close proximity to the discharge stack.

Termination of discharge pipe

3.61 The discharge pipe (D2) from the tundish should terminate in a safe place where there is no risk to persons in the vicinity of the discharge.

3.62 Examples of acceptable discharge arrangements are:

- (a) to a trapped gully with the end of the pipe below a fixed grating and above the water seal;
- (b) downward discharges at low level; i.e. up to 100mm above external surfaces such as car parks, hard standings, grassed areas etc. are acceptable providing that a wire cage or similar guard is positioned to prevent contact, whilst maintaining visibility; and
- (c) discharges at high level: e.g. into a metal hopper and metal downpipe with the end of the discharge pipe clearly visible or onto a roof capable of withstanding high temperature discharges of water and 3m from any plastic guttering system that would collect such discharges.

3.63 The discharge would consist of high temperature water and steam. Asphalt, roofing felt and non-metallic rainwater goods may be damaged by such discharges.

Worked example of discharge pipe sizing

Fig. 9: shows a G1/2 temperature relief valve with a discharge pipe (D2) having 4 No. elbows and length of 7m from the tundish to the point of discharge.

From Table 5:

Maximum resistance allowed for a straight length of 22mm copper discharge pipe (D2) from a G1/2 temperature relief valve is 9.0m.

Subtract the resistance for 4 No. 22mm elbows at 0.8m each = 3.2m.

Therefore the permitted length equates to: 5.8m.

5.8m is less than the actual length of 7m therefore calculate the next largest size.

Maximum resistance allowed for a straight length of 28mm pipe (D2) from a G1/2 temperature relief valves equates to 18m.

Subtract the resistance of 4 No. 28mm elbows at 1.0m each = 4.0m

Therefore the maximum permitted length equates to: 14m.

As the actual length is 7m, a 28mm (D2) copper pipe will be satisfactory.

Table 5: Sizing of copper discharge pipe (D2) for common temperature relief valve outlet sizes

Valve Outlet Size	Minimum Size Of Discharge Pipe D1	Minimum Size Of Discharge Pipe D2 From Tundish	Maximum Resistance Allowed, Expressed As A Length Of Straight Pipe (I.E. No Elbows Or Bends)	Resistance Created By Each Elbow Or Bend
G1/2	15mm	22mm 28mm 35mm	up to 9m up to 18m up to 27m	0.8m 1.0m 1.4m
G3/4	22mm	28mm 35mm 42mm	up to 9m up to 18m up to 27m	1.0m 1.4m 1.7m
G1	28mm	35mm 42mm 54mm	up to 9m up to 18m up to 27m	1.4m 1.7m 2.3m

Figure 9: Typical discharge pipe arrangement (extract from Building Regulation G3 Guidance Section 3.50)

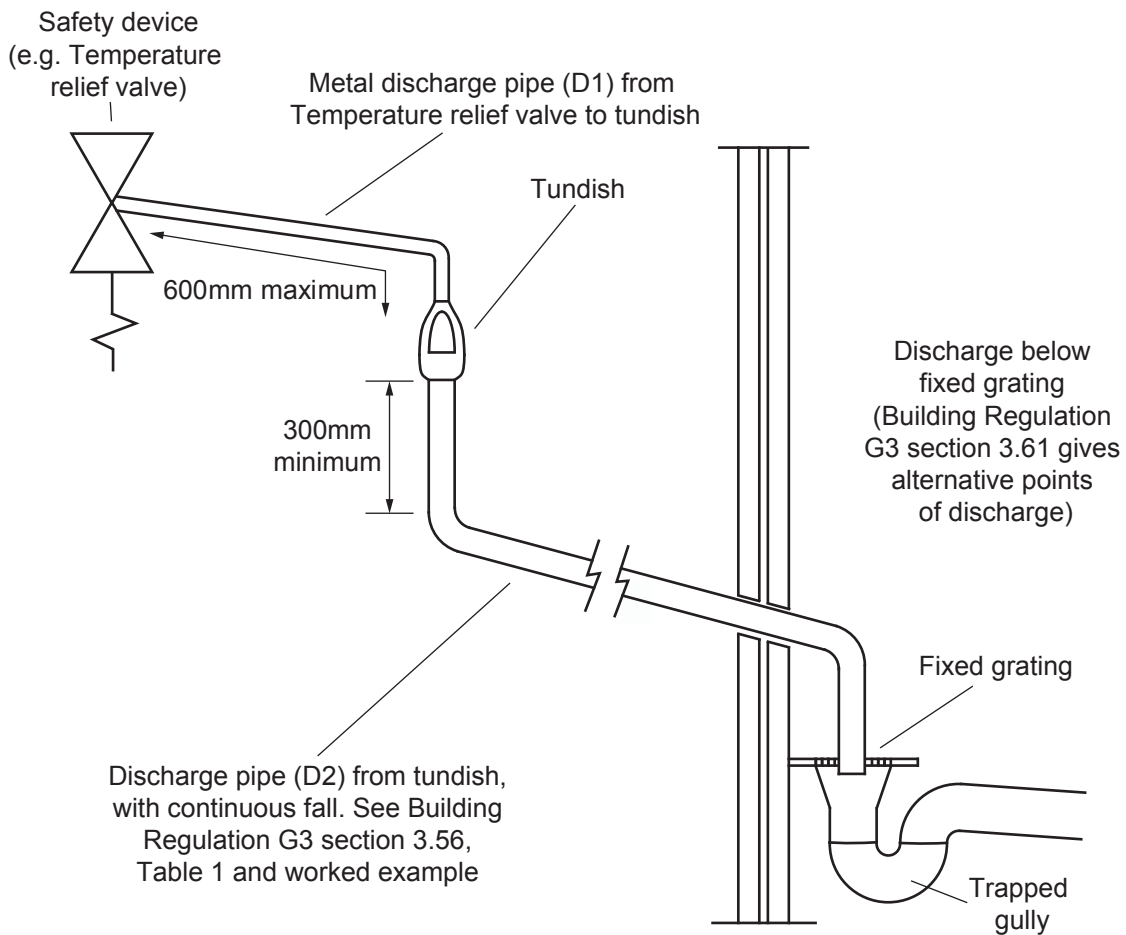

6.3 Electrical connections

In case of difficulty, customer service contact details are available on page 40 of this manual.



WARNING

- ▶ Disconnect from the mains electrical supply before removing any covers.
- ▶ Never attempt to replace the immersion heater(s) other than with genuine manufacturers components. Using other manufactureres components may invalidate the warranty on the cylinder.
- ▶ DO NOT bypass the thermal cut-out(s) in any circumstances.
- ▶ All electrical wiring should be carried out by a competent electrician and be in accordance with the latest I.E.E Wiring Regulations.
- ▶ Each circuit must be protected by a suitable fuse and double pole isolating switch with a contact separation of at least 3mm in both poles.
- ▶ DO NOT operate the immersion heaters until the appliance has been filled with water.

DIRECT models

- ▶ The immersion heater and controls are accessed by removing the Control Cover (see Fig. 10).
- ▶ Unscrew the large screw on the cover using a flat ended screwdriver.
- ▶ Lift from the bottom of the cover at the point

Figure 10: Immersion heater cover removal and replacement

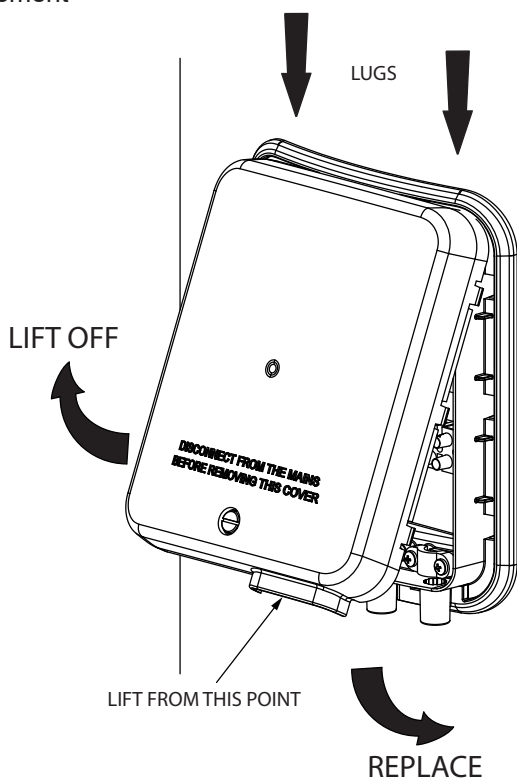

indicated on Fig. 10 until cover comes away freely.

- ▶ Where the cylinders are fitted with two immersion heaters. Each immersion heater is rated 3kW at 240V ~ 1ph.
- ▶ The immersion heater(s) should be wired in accordance with Fig. 11. The immersion heater(s) MUST be earthed. The supply cable should be a minimum 1.5mm² 3 core HO5 VV-F sheathed cable and must be routed through the cable entry ports

Figure 11: Wiring schematic - DIRECT models

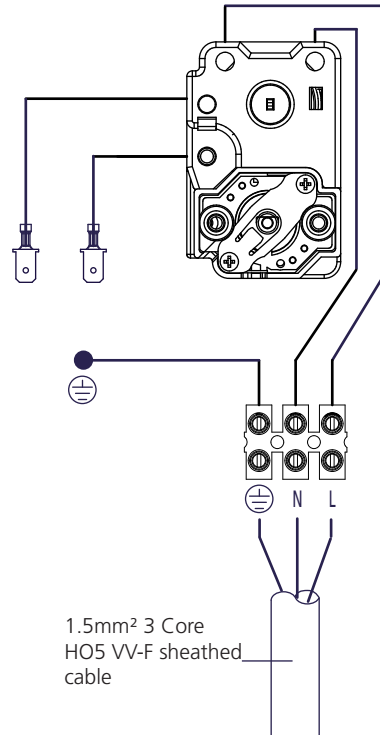

provided with the outer sheath of the cable firmly secured using the cable securing bar provided.

- ▶ The immersion heater thermostat is factory set at 57°C. This is set for eco mode. To maximise water availability the thermostat should be set to maximum during commissioning (see Fig. 12, page 20). Should this require adjustment, see Fig. 12 for details of how to adjust the temperature setting. Each immersion heater has its own individual thermostatic control. The thermostat incorporates a thermal cut-out that will switch off the immersion heater in the event of a thermostat failure. The thermal cut-out reset button position is also shown on Fig. 12.
- ▶ Replace the Control Cover(s) before operating. To do this tilt the cover and align the top two lugs with the holes in the housing as indicated on Fig. 10. Hinge the cover downwards and firmly press the cover until it "snaps" back into place. Secure by tightening the screw on the cover using a flat ended screwdriver. DO NOT OVER TIGHTEN.

Figure 12: Thermostat adjustment

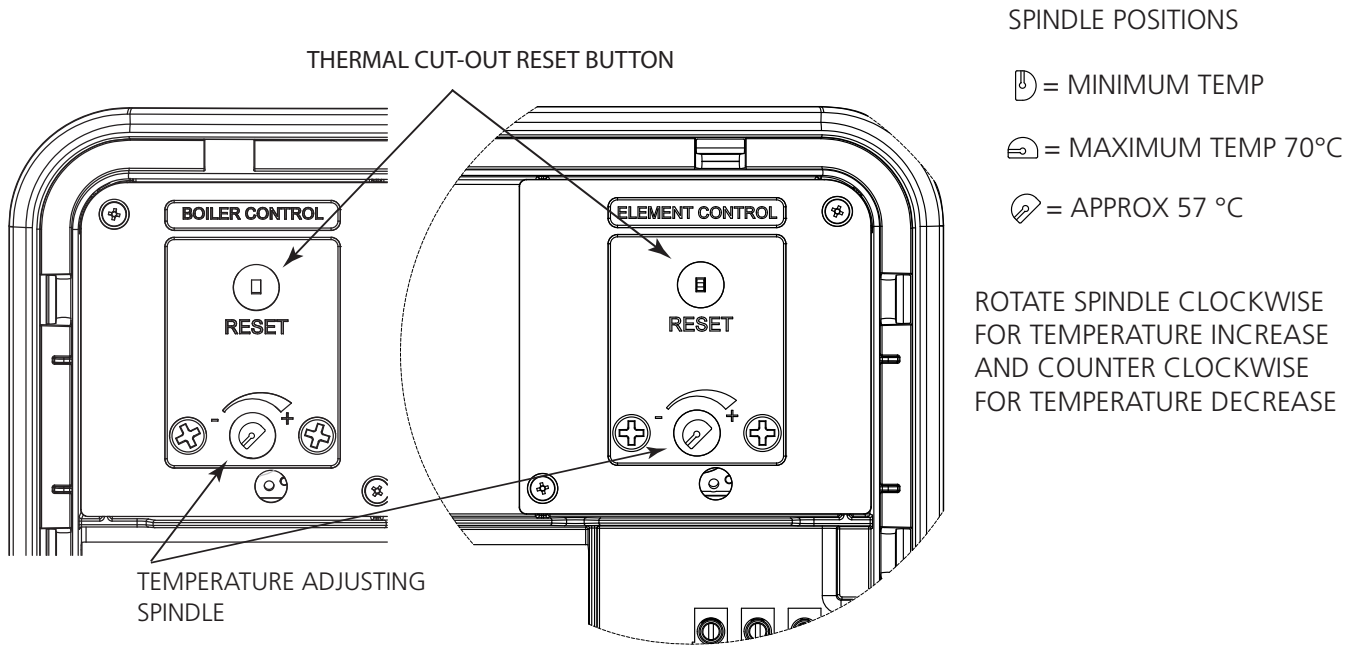

INDIRECT models

- ▶ The indirect controls and back-up immersion heater are accessed by removing the Control Cover (see Fig. 10, pages 19).
- ▶ Unscrew the large screw on the cover using a flat ended screwdriver.
- ▶ Lift from the bottom of the cover at the point indicated on Fig. 10 until cover comes away freely.
- ▶ The back up immersion heater should be wired in accordance with the instructions given for DIRECT models. The immersion heater cannot be controlled by the boiler control or space heating programmer, it must be connected with its own dedicated electrical supply circuit.
- ▶ The immersion heater and indirect thermal controls should be wired in accordance with Fig. 13.
- ▶ The immersion heater and indirect controls **MUST** be earthed. The supply cable for the immersion heater should be a minimum 1.5mm² 3 core HO5

VV-F sheathed cable and must be routed through the right hand cable entry port provided, with the outer sheath of the cable firmly secured using the cable securing bar provided. The cable connecting the indirect control to the heating system must be an appropriate size for the maximum load of the heating controls and should be routed in the controls housing through the left hand cable entry port and secured using the cable securing bar provided.

- ▶ The immersion heater and boiler control thermostats are factory set at 57°C. See Fig. 12 for details of how to adjust the temperature setting. The immersion heater and indirect controls each has its own individual thermostatic control. The thermostats incorporate a thermal cut-out that will switch off in the event of a thermostat failure. The thermal cut-out reset button position is also shown on Fig. 12.
- ▶ Replace the Control Cover(s) before operating. To do this tilt the cover and align the top two lugs with the holes in the housing as indicated on Fig. 10. Hinge the cover downwards and firmly press the cover until it "snaps" back into place. Secure by tightening the screw on the cover using a flat ended screwdriver. **DO NOT OVER TIGHTEN.**

Figure 13: Wiring schematic - INDIRECT models

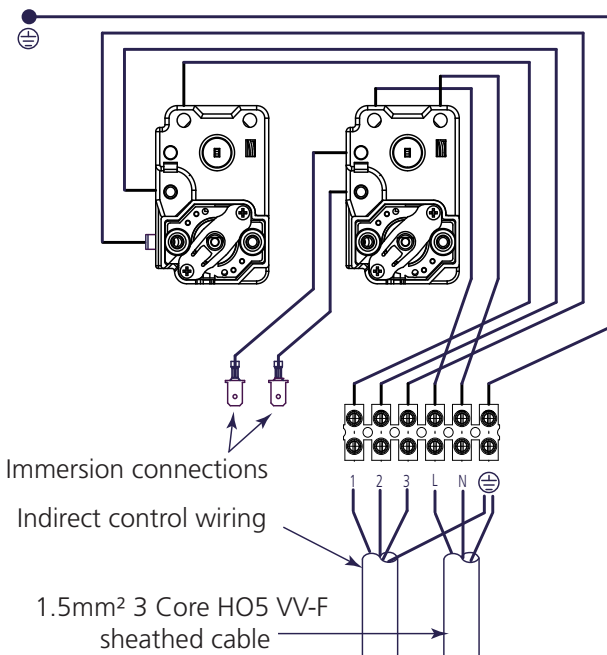

Space and heating systems controls

- ▶ The controls provided with the cylinder will ensure the safe operation of the unit within the central heating system. Other controls will be necessary to control the space heating requirements and times that the system is required to function.
- ▶ The cylinder is compatible with most heating controls, examples of electrical circuits are shown in Fig. 14 & 15, page 21. However, other systems may be suitable, refer to the controls manufacturers instructions, supplied with the controls selected, for alternative system wiring schemes.

Figure 14: Wiring schematic - 2 x 2 Port valve heating system

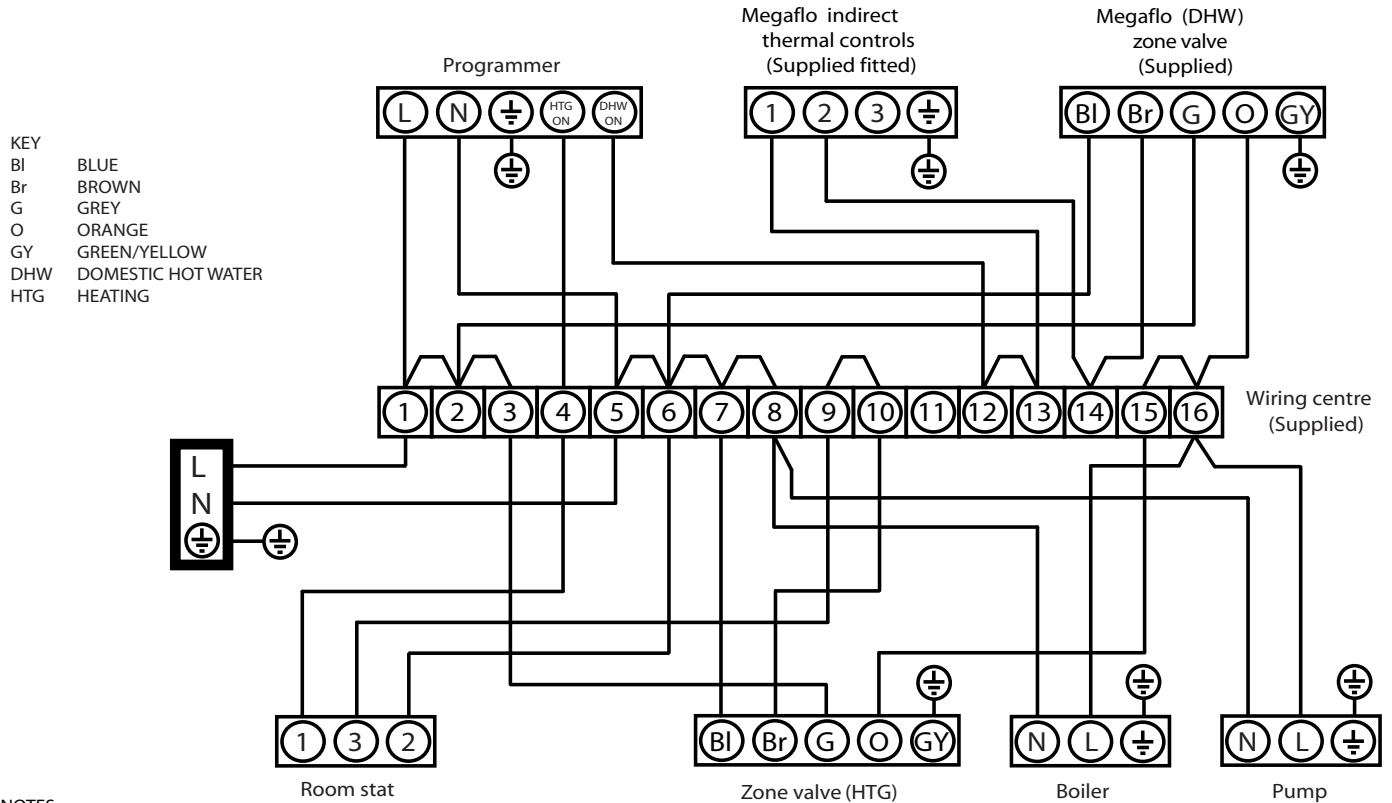

NOTES:

1. A DOUBLE POLE ISOLATING SWITCH MUST BE INSTALLED IN THE MAINS SUPPLY.
2. ALL EARTH CONNECTIONS MUST BE LINKED BACK TO THE MAINS EARTH SUPPLY.
3. USE COPPER LINKS SUPPLIED TO MAKE CONNECTIONS BETWEEN TERMINALS.
4. DO NOT MOUNT WIRING CENTRE ON CYLINDER.
5. THE ABOVE DIAGRAM IS FOR GUIDANCE ONLY, HEATRAE SADIA ACCEPT NO LIABILITY FOR ANY LOSS OR DAMAGE ARISING FROM ANY ERRORS OR OMISSIONS. THAT MAY BE INADVERTENTLY CONTAINED WITHIN THIS DIAGRAM. THE VARIOUS EQUIPMENT MANUFACTURERS SHOULD BE CONSULTED TO CONFIRM THE CORRECT OPERATION OF THEIR PRODUCTS WITHIN THE SYSTEM.

Figure 15: Wiring schematic - 2 Port valve in conjunction with 3 port mid-position valve heating system

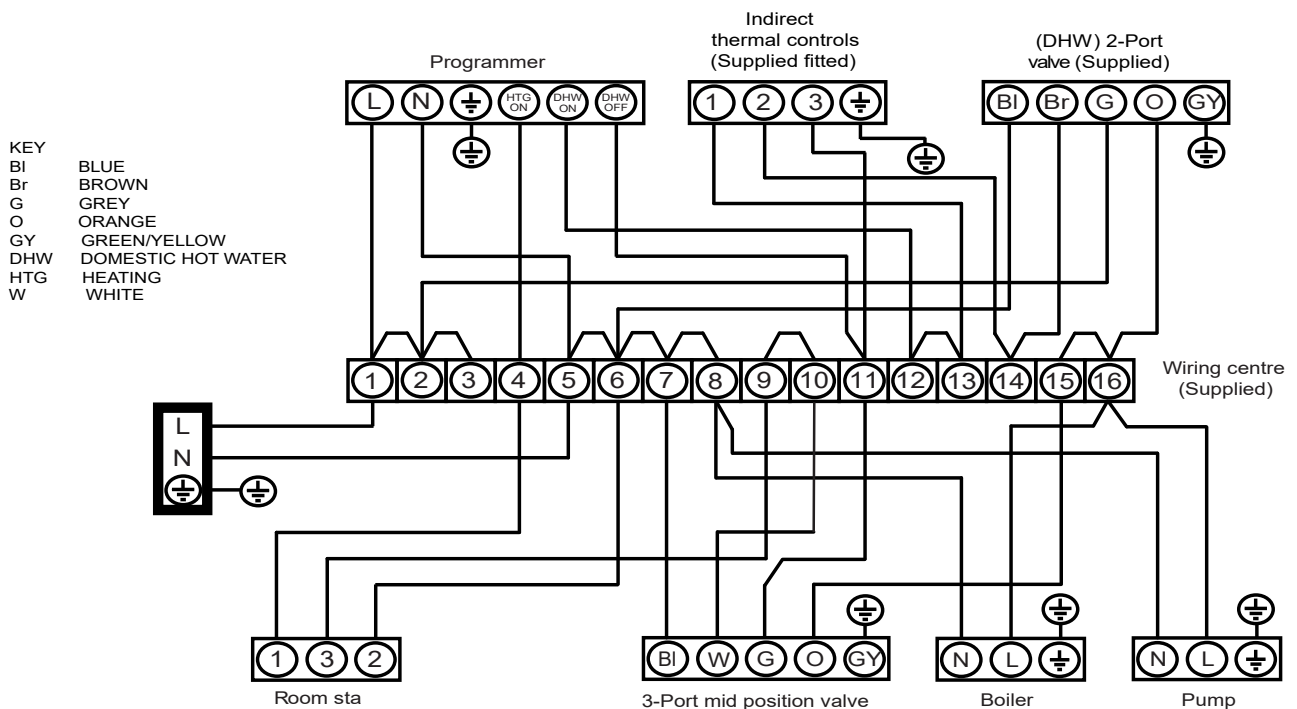

NOTES:

1. A DOUBLE POLE ISOLATING SWITCH MUST BE INSTALLED IN THE MAINS SUPPLY.
2. ALL EARTH CONNECTIONS MUST BE LINKED BACK TO THE MAINS EARTH SUPPLY.
3. ASSUMES BASIC BOILER WITH EXTERNAL PUMP.
4. USE COPPER LINKS SUPPLIED TO MAKE CONNECTIONS BETWEEN TERMINALS.
5. DO NOT MOUNT WIRING CENTRE ON CYLINDER.
6. THE ABOVE DIAGRAM IS FOR GUIDANCE ONLY, BAXI ACCEPT NO LIABILITY FOR ANY LOSS OR DAMAGE ARISING FROM ANY ERRORS OR OMISSIONS. THAT MAY BE INADVERTENTLY CONTAINED WITHIN THIS DIAGRAM. THE VARIOUS EQUIPMENT MANUFACTURERS SHOULD BE CONSULTED TO CONFIRM THE CORRECT OPERATION OF THEIR PRODUCTS WITHIN THE SYSTEM.



WARNING

Should the cylinder be used in conjunction with a boiler or external controls that control the water temperature via a sensor connected to the cylinder, it should be noted that the factory fitted indirect thermostat and thermal cut-out **MUST NOT** be disconnected or bypassed. To do so would invalidate the product approvals and warranty and it would not comply with Building Regulations. Should this method of control be adopted then the cylinder thermostat should be set at a maximum temperature of 70°C to avoid the thermostat over-riding the boiler control.

Where the boiler or external controls do not directly power the 2 Port Motorised Valve supplied with the cylinder, the wiring should ensure that in the event of the thermal cut-out on the cylinder controls operating power will be interrupted to the 2 Port Motorised Valve such that it closes and prevents flow of the primary heating fluid around the Megaflo primary heat exchanger coil.

For further details of wiring the boiler, or external controls consult the manufacturer's installation instructions.

Any controls fitted should be compatible with mains 230/240vAC and should be wired in to operate the 2-port valve via the cylinder controls supplied/fitted.

▶ **6.4 Filling the appliance**

- ▶ Ensure the drain cock is **CLOSED**.
- ▶ Open a hot tap furthest from the appliance.
- ▶ Open the mains stop cock.
- ▶ Open the isolating valve by turning the blue handle so it is parallel with the direction of flow. It should be fully opened, partial opening will restrict the inlet flow rate.
- ▶ Allow the appliance to fill. When water flows from the tap, allow to run for a few minutes to thoroughly flush through any residue, dirt or swarf, then close the tap.
- ▶ Open successive hot taps to purge the system of air.
- ▶ Check all connections and system pipes for water tightness.



WARNING

DO NOT operate the immersion heaters or primary circuit until the appliance has been filled with water.

7. Commissioning

7.1 General

After filling the installation with water in the previous section please follow the following steps to complete the installation of the unit.



WARNING

DO NOT operate the immersion heaters or primary circuit until the appliance has been filled with water.



WARNING

- ▶ If the unit is to be left unused following installation and commissioning e.g. unoccupied properties, the water heater should be drained or regularly flushed through with fresh mains water once a week.
- ▶ When placing the unit into service, the procedure for filling the unit and the system checks below should be observed.

7.2 Checklist before commissioning

- ▶ Check all water connections for leaks and rectify as necessary.
- ▶ Turn off mains water supply.
- ▶ Remove the pressure reducing valve head work to access the strainer mesh, clean and re-fit.
- ▶ Turn the water supply back on.
- ▶ Manually open, for a few seconds, each relief valve in turn, checking that water is discharged and runs freely through the tundish and out at the discharge point.
- ▶ Ensure that the valve(s) reseal satisfactorily.

7.3 Commissioning procedure

Direct units

- ▶ Switch on electrical supply to the immersion heater(s) and allow the water heater to heat up to normal working temperature, factory set to 57°C.
- ▶ Adjust the temperature by inserting a flat bladed screwdriver in the adjustment spindle on front of the immersion heater (ELEMENT) control thermostat and rotating (see Fig. 12, page 20 for details of how to adjust). The adjustment represents a temperature range of 10°C to 70°C.
- ▶ Check the operation of thermostat(s) and that no water has issued from the Expansion Relief Valve or Temperature/Pressure Relief Valve during the heating cycle.

Indirect units

- ▶ Fill the indirect (primary) circuit following the boiler manufacturer's commissioning instructions.
- ▶ To ensure the cylinder primary heat exchanger is filled, the 2 port motorised valve (supplied) should be manually opened by moving the lever on the motor housing to the MANUAL setting. When the primary circuit is full return the lever to the AUTOMATIC position.
- ▶ Switch on the boiler, ensure the programmer is set to Hot Water and allow the cylinder to heat up to a normal working temperature, 57°C.
- ▶ If necessary adjust the temperature by inserting a flat bladed screwdriver in the adjustment spindle on front of the indirect (BOILER) thermostat and rotating (see Fig. 12, page 20 for details of how to adjust). The adjustment represents a temperature range of 10°C to 70°C.
- ▶ Check the operation of thermostat(s) and that no water has issued from the Expansion Relief Valve or Temperature/Pressure Relief Valve during the heating cycle.

7.4 Benchmark

The appliance is covered by the Benchmark Scheme which aims to improve the standards of installation and commissioning of domestic heating and hot water systems in the UK and to encourage regular servicing to optimise safety, efficiency and performance.

Benchmark is managed and promoted by the Heating and Hotwater Industry Council. For more information visit www.centralheating.co.uk.

Please ensure that the installer has fully completed the Benchmark Checklist (see page 34) of this manual and that you have signed it to say that you have received a full and clear explanation of its operation. The installer is legally required to complete a commissioning checklist as a means of complying with the appropriate Building Regulations (England & Wales).

All installations must be notified to Local Area Building Control either directly or through a Competent Persons Scheme. A Building Regulations Compliance Certificate will then be issued to the customer who should, on receipt, write the Notification Number on the Benchmark Checklist.

This product should be serviced regularly to optimise its safety, efficiency and performance. The service engineer should complete the relevant Service Record on the Benchmark Checklist after each service.

The Benchmark Checklist may be required in the event of any warranty work.

8. Operation

8.1 General



WARNING

- ▶ If water discharges from the Temperature & Pressure relief valve on the cylinder shut down the heat source and/or switch off the immersion heater(s). DO NOT turn off the water supply. Contact a competent installer for unvented water heaters to check the system.
- ▶ DO NOT tamper with any of the safety valves fitted to the system. If a fault is suspected contact a competent installer.
- ▶ Disconnect from the mains electrical supply before removing any covers.
- ▶ DO NOT bypass the thermal cut-out(s) in any circumstances.
- ▶ All electrical wiring should be carried out by a competent electrician and be in accordance with the latest I.E.E Wiring Regulations.

Temperature controls – direct units immersion heater(s)

- ▶ A combined thermostat and thermal cut-out is provided for each immersion heater fitted. The thermostat is factory set to give a water storage temperature of approx. 57°C, however it can be set to control between 10°C and 70°C.
- ▶ To access the thermostat open the controls housing cover (see Fig. 10, page 19) - DISCONNECT THE ELECTRICAL SUPPLY BEFORE OPENING THE COVER(S).
- ▶ Temperature adjustment is made by rotating the adjustment spindle on the top of the thermostat. The adjustment represents a temperature range of 10°C to 70°C (Fig. 12, see page 20 for method of adjustment).
- ▶ Maximum working temperature is 70°C.

DO NOT bypass the thermal cut-out(s) in any circumstances.

Temperature controls - indirect units

- ▶ A combined thermostat and thermal cut-out is provided for the control of the external boiler. The thermostat is factory set to give a water storage temperature of approx. 57°C, however it can be set to control between 10°C and 70°C. Adjustments can only be made by opening the controls covers.
- ▶ To access the thermostat open the controls housing cover see Fig. 10, page 19



WARNING

- ▶ DISCONNECT THE ELECTRICAL SUPPLY BEFORE OPENING THE COVER(S).

- ▶ Temperature adjustment is made by rotating the adjustment spindle on the top of the thermostat. The adjustment represents a temperature range of 10°C to 70°C (see Fig. 12, page 20 for method of adjustment).
- ▶ Maximum working temperature is 70°C.
- ▶ The boiler thermostat and thermal cut-out must be wired in series with the 2 port motorised zone valve supplied to interrupt the flow of primary water around the heat exchanger coil when the control temperature has been reached.
- ▶ The controls fitted to the cylinder will affect the temperature of the stored water only, other controls will be provided in the system for time and temperature control of the space heating requirements. Consult the instructions provided with those controls for details of adjustments.

DO NOT bypass the thermal cut-out(s) in any circumstances.

Flow performance

When initially opening hot outlets a small surge in flow may be noticed as pressures stabilise. This is quite normal with unvented systems. In some areas cloudiness may be noticed in the hot water. This is due to aeration of the water, is quite normal and will quickly clear.

Operational faults

Operational faults and their possible causes are detailed in section 10. Troubleshooting, page 27 of this manual. It is recommended that faults should be checked by a competent installer.

9. Maintenance

9.1 General

Maintenance requirements

Only competent persons having received adequate training are permitted to work on the appliance and the installation. Unvented hot water systems have a continuing maintenance requirement in order to ensure safe working and optimum performance. It is essential that the relief valve(s) are periodically inspected and manually opened to ensure no blockage has occurred in the valves or discharge pipework.

Similarly cleaning of the strainer element and replacement of the air in the internal expansion volume will help to prevent possible operational faults.

The maintenance checks described below should be performed by a competent person on a regular basis, e.g. **annually** to coincide with boiler maintenance.

After any maintenance, please complete the relevant Service Record section of the Benchmark Checklist on page 35 of this document.

9.2 Standard inspection & maintenance operations

Inspection

The immersion heater boss can be used as an access for inspecting the cylinder internally.

Safety valve operation



CAUTION

Water discharged may be very hot!

- ▶ Manually operate the Temperature/Pressure Relief Valve for a few seconds (Fig. 3, page 9).
- ▶ Check water is discharged and that it flows freely through the tundish and discharge pipework.
- ▶ Check valve reseats correctly when released.
- ▶ Repeat the above procedure for the Expansion Relief Valve. (Fig. 3, page 9).

Strainer

- ▶ Turn off the isolating valve prior to the Pressure Reducing Valve or the main stop cock to the system.
- ▶ Open the lowest hot tap in the system to relieve the system pressure.
- ▶ Using a spanner unscrew the Pressure Reducing Valve cartridge and remove the housing. The strainer will be removed with the cartridge. (see Fig. 16, page 30).
- ▶ Wash any particulate matter from the strainer under clean running water.

- ▶ Replace the strainer and screw the Pressure Reducing Valve cartridge into the moulded housing.
- ▶ Close hot tap, turn on isolating valve or main stop cock to the system. Check for leaks.

Descaling immersion heater(s)



CAUTION

DO NOT use a sharp implement as damage to the element surface could be caused.

Turn off the mains water supply, isolate the electrical supply and turn off boiler.

- ▶ Attach a hosepipe to the drain cock having sufficient length to take water to a suitable discharge point below the level of the unit.
- ▶ Open a hot tap close to the unit and open drain cock to drain the cylinder.
- ▶ Open the cover(s) to the immersion heater housing(s) and disconnect wiring from immersion heater(s) thermostat(s).
- ▶ Unscrew the immersion heater backnut using the tool supplied and withdraw the immersion heater from the cylinder. Take care when removing the immersion heater from the cylinder and work within safe working practices.
- ▶ Carefully remove any scale from the surface of the element(s).
- ▶ Ensure sealing surfaces are clean. Fit a new gasket (spare part no. 7035165).
- ▶ Replace immersion heater(s), making sure the gasket is correctly fitted and does not become displaced as the immersion heater is replaced.
- ▶ Rewire, check, close and secure immersion heater housing cover(s).

Re-commissioning

- ▶ Check all electrical and plumbing connections are secure. Close the drain cock.
- ▶ With a hot tap open, turn on the cold water supply and allow appliance to refill.
- ▶ DO NOT switch on the immersion heater(s) or boiler until the appliance is full.
- ▶ When water flows from the hot tap allow to flow for a short while to purge air and flush through any disturbed particles.
- ▶ Close hot tap and then open successive hot taps in system to purge any air.
- ▶ When completely full and purged check system for leaks.
- ▶ The heating source (immersion heater(s) or boiler) can then be switched on.

Expansion volume re-charge

The air volume within the product will periodically require recharging to ensure expanded water is accommodated within the system. A discharge of water INTERMITTENTLY from the expansion valve will indicate the air volume has reduced to a point where it can no longer accommodate the expansion.



<https://www.baxi.co.uk/trade/technical-support/technical-support-video-guides>

To recharge the air volume:-

- ▶ Turn off the heat source to the cylinder via programmers / immersion isolation switch(es).
- ▶ Turn off the water supply to the cylinder by turning off the isolating valve on the 3 bar pressure reducing valve if fitted at this point. Turn the handle so that it lies at 90° to the direction of flow.
- ▶ Open the lowest hot tap in the property. This could be a sink, basin, bath tap etc..
- ▶ Hold open the temperature / pressure relief valve until water ceases to run from the tap and gurgling noise at the valve stops, (see Fig. 3, page 9).
- ▶ Close the temperature / pressure relief valve.
- ▶ Turn on the isolating valve at the cold water combination valve by turning the handle so it lies parallel to the direction of flow, when water flows from the hot tap, close tap.
- ▶ The air volume will be automatically recharged as the unit refills. If after following the above actions water still discharges from the expansion relief valve, further advice should be sought from a competent installer or the Baxi service department.

10. Troubleshooting



WARNING

Do not tamper with any of the safety valves or controls supplied with the cylinder as this will invalidate any warranty.

Water contained in the cylinder may be very hot, especially following a thermal control failure. Caution must be taken when drawing water from the unit.

NEVER bypass any thermal controls or operate system without the necessary safety valves.

- ▶ After servicing, complete the relevant Service Interval Record section of the Benchmark Checklist located on page 35 of this document.
- ▶ Any spare parts used MUST be authorised parts.
- ▶ Disconnect the electrical supply before removing any electrical equipment covers.
- ▶ NEVER bypass any thermal controls or operate system without the necessary safety valves.

The fault finding chart (Table 6, below) will enable operational faults to be identified and their possible causes rectified. Any work carried out on the unvented appliance and its associated controls MUST be carried out by a competent installer for unvented water heating systems. In case of doubt contact customer service. (see page 40 for details).

Spare Parts

A full range of spare parts are available for the cylinder range (Table 7, page 29). Refer to the technical data label on the unit to identify the model installed and ensure the correct part is ordered. You will need to quote the serial number, which is printed on the data label.

10.1 Fault finding

Important

- ▶ Servicing should only be carried out by competent persons in the installation and maintenance of unvented water heating systems.

Table 6: Fault finding chart

Fault	Possible cause	Remedy
No hot water	1. Mains water supply off.	1. Check and open stop cock.
	2. Strainer blocked.	2. Turn off water supply. Remove strainer and clean (see page 25 for details).
	3. Pressure reducing valve incorrectly fitted.	3. Check and refit as required.
Water from hot taps is cold	1. Immersion heater not switched on.	1. Check and switch on.
	2. Immersion heater thermal cut-out has tripped.	2. Check. Reset by pushing button (see Fig. 12, page 20).
	3. Indirect programmer set to central heating only.	3. Check. Set programmer to a hot water programme.
	4. Indirect boiler not working.	4. Check boiler operation. If fault is suspected consult boiler manufacturers instructions.
	5. Indirect thermal cut-out has tripped.	5. Check. Reset by pushing button. Check operation of indirect thermostat (see Fig. 13, page 20).
	6. Indirect motorised valve not connected correctly.	6. Check wiring and/or plumbing connections to motorised valve (see Fig. 14 & 15, page 21).
Water discharges from expansion relief valve	1. Intermittently. Air volume in the cylinder has reduced	1. See page 26 for details on how to test and recharge.
	2. Continually. 3 bar pressure reducing valve is not working correctly.	2. Check pressure from 3 bar Pressure Reducing Valve. If greater than 3 bar replace Pressure Reducing Valve.
	3. Continually. Expansion valve seat damaged.	3. Replace combined T&P/Expansion relief valve assembly
Water discharges from the T&P valve intermittently	1. Air volume in the cylinder has reduced	1. See page 26 for details on how to test and recharge.
	2. 8 bar expansion relief valve faulty.	2. Check valve and replace if necessary
Water discharges from the T&P valve continually	1. Thermal control failure. Note water will be very hot.	1. Switch off power supply to immersion heater(s) and shut down the boiler. DO NOT turn off the water supply. When discharge stops check all thermal controls, replace if faulty.
Milky water	1 Oxygenated water.	1. Water from a pressurised system releases oxygen bubbles when flowing. The milky water will disappear after a short while.

11. Decommissioning

11.1 Decommissioning procedure

- ▶ Isolate electrical supplies and make safe
- ▶ Isolate the water supply
- ▶ Drain the appliance
- ▶ Drain the primary circuit (indirect only)
- ▶ Remove appliance
- ▶ Cap pipework

Environmental information

Products are manufactured from many recyclable materials. At the end of their useful life they should be disposed of at a Local Authority Recycling Centre in order to realise the full environmental benefits.

Insulation is by means of an approved CFC/HCFC free polyurethane foam with an ozone depletion factor of zero.

WEEE Declaration

Disposal of Waste Equipment by Users in Private Households in the European Union.

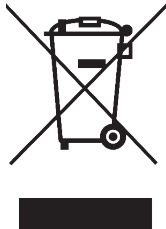

This symbol on the product indicates that this product must not be disposed of with your other household waste. Instead, it is your responsibility to dispose of your waste equipment by handing it over to a designated collection point for the recycling of waste electrical equipment. The separate collection and recycling of your waste equipment at the time of disposal will help to conserve natural resources and ensure that it is recycled in a manner that protects human health and the environment. For more information about where you can drop off your waste equipment for recycling, please contact your local city office, your household waste disposal service or the company where this product was purchased.

12. Spare parts

12.1 Spare parts list

A full range of spare parts are available for the Baxi cylinder range. Refer to the Technical Data label on the unit to identify the model installed and ensure the correct part is ordered.

Table 7: Spare parts list - Indirect

Item	Description	Part number
3	IMMERSION HEATER GASKET	7702935
7	T & P VALVE 90DEG C/10BAR	95605209
11	DIRECT COMBINED THERMOSTAT / THERMAL CUT-OUT	7031688
14	INDIRECT ELEMENT - INCOLOY (BENT, LOWER)	95606984
15	IMMERSION HEATER BACKNUT - PLASTIC (BLACK)	95605132
16	INDIRECT COMBINED THERMOSTAT / THERMAL CUT-OUT	7031689
17	CONTROL COVER ASSY - KIT	7826649
18	INDIRECT MOUNTING PLATE	95607931
19	6 WAY TERMINAL BLOCK	95607933
21	1/2" BSP SENSOR PCCKET ASSEMBLY LONG	7032579
	COLD WATER INLET CONTROL KIT: (NOT SHOWN)	95605894
	3 BAR PRESSURE REDUCING VALVE COMPLETE	
	8 BAR PRESSURE RELIEF VALVE COMPLETE	
	STOPCOCK/ ISOLATING VALVE	
	3 BAR PRESSURE REDUCING VALVE (SHOWN ON PAGE 31)	95605886
	3 BAR PRESSURE REDUCING VALVE CARTRIDGE (SHOWN ON PAGE 31)	95605891
	PRESSURE RELIEF VALVE COMPLETE - 8 BAR (SHOWN ON PAGE 31)	95605893
	8 BAR PRESSURE RELIEF CARTRIDGE (SHOWN ON PAGE 31)	95605888
	STOPCOCK/ ISOLATING VALVE (SHOWN ON PAGE 31)	95605885
	SWEPT TEE JOINT (FOR SECONDARY RETURN) (NOT SHOWN)	95605812
	IMMERSION HEATER BLANKING PLATE - 210L - 300L Only (NOT SHOWN)	95605881
	DRAIN VALVE 1/4 TURN (NOT SHOWN)	95605051
	TUNDISH 15x22MM (NOT SHOWN)	95605838
	IMMERSION HEATER KEY SPANNER (NOT SHOWN)	95607861
	SET OF COMPRESSION NUTS AND OLIVES (NOT SHOWN)	95607838

Table 8: Spare parts list - Direct

Item	Description	Part number
3	IMMERSION HEATER GASKET	7702935
7	T & P VALVE 90DEG C/10BAR	95605209
11	DIRECT COMBINED THERMOSTAT / THERMAL CUT-OUT	7031688
12	DIRECT MOUNTING PLATE - COMBINED THERMOSTAT / THERMAL CUT-OUT	95607929
13	3 WAY TERMINAL BLOCK	7034185
14	INDIRECT ELEMENT - INCOLOY (BENT, LOWER)	95606984
15	IMMERSION HEATER BACKNUT - PLASTIC (BLACK)	95605132
17	CONTROL COVER ASSY - KIT	7826649
22	IMMERSION HEATER - UPPER	95606986
	COLD WATER INLET CONTROL KIT: (NOT SHOWN)	95605894
	3 BAR PRESSURE REDUCING VALVE COMPLETE	
	8 BAR PRESSURE RELIEF VALVE COMPLETE	
	STOPCOCK/ ISOLATING VALVE	
	3 BAR PRESSURE REDUCING VALVE (SHOWN ON PAGE 31)	95605886
	3 BAR PRESSURE REDUCING VALVE CARTRIDGE (SHOWN ON PAGE 31)	95605891
	PRESSURE RELIEF VALVE COMPLETE - 8 BAR (SHOWN ON PAGE 31)	95605893
	8 BAR PRESSURE RELIEF CARTRIDGE (SHOWN ON PAGE 31)	95605888
	STOPCOCK/ ISOLATING VALVE (SHOWN ON PAGE 31)	95605885
	SWEPT TEE JOINT (FOR SECONDARY RETURN) (NOT SHOWN)	95605812
	DRAIN VALVE 1/4 TURN (NOT SHOWN)	95605051
	TUNDISH 15x22MM (NOT SHOWN)	95605838
	IMMERSION HEATER KEY SPANNER (NOT SHOWN)	95607861
	SET OF COMPRESSION NUTS AND OLIVES (NOT SHOWN)	95607838

Figure 16: Pressure Reducing Valve exploded view

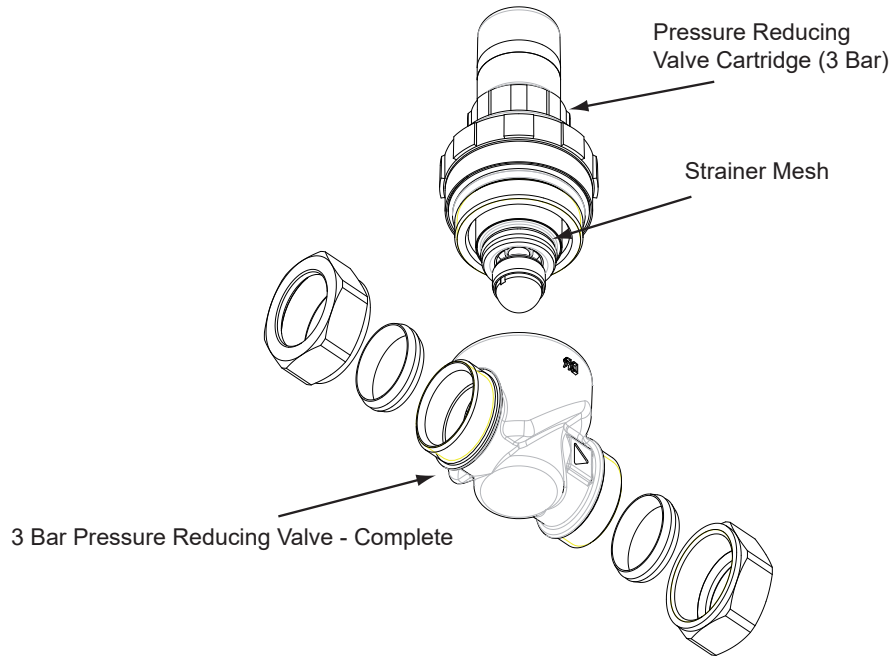

PRV WARNING:

IF THERE IS AN UPSTREAM CHECK VALVE OR FITTING WHICH MAY PREVENT BACKFLOW THEN HIGH PRESSURES CAN BE EXPERIENCED DUE TO AMBIENT TEMPERATURES WHICH CAN CAUSE DAMAGE TO THE VALVES AND FITTINGS

Figure 17: Pressure Reducing Valve exploded view

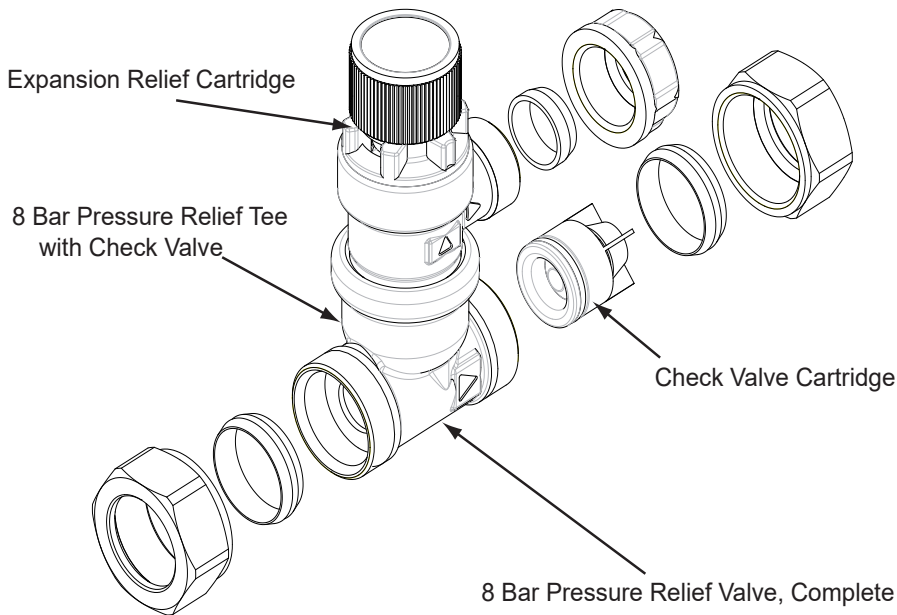

Figure 18: Pressure Reducing Valve exploded view

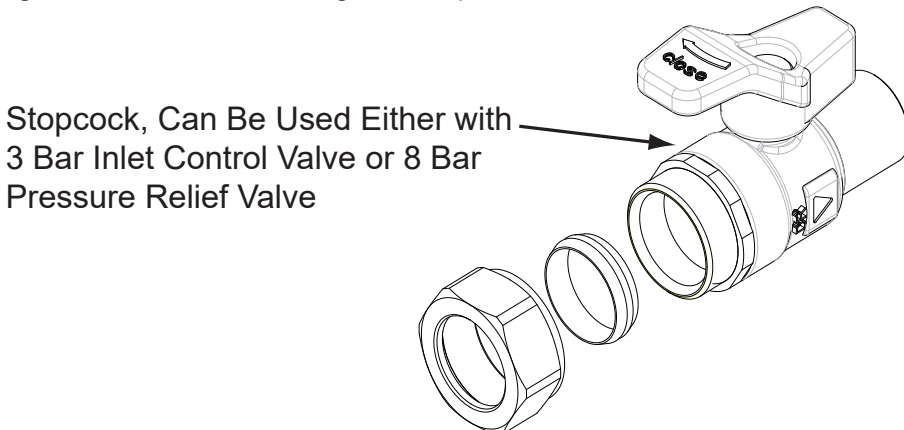

Figure 19: Indirect controls - exploded view

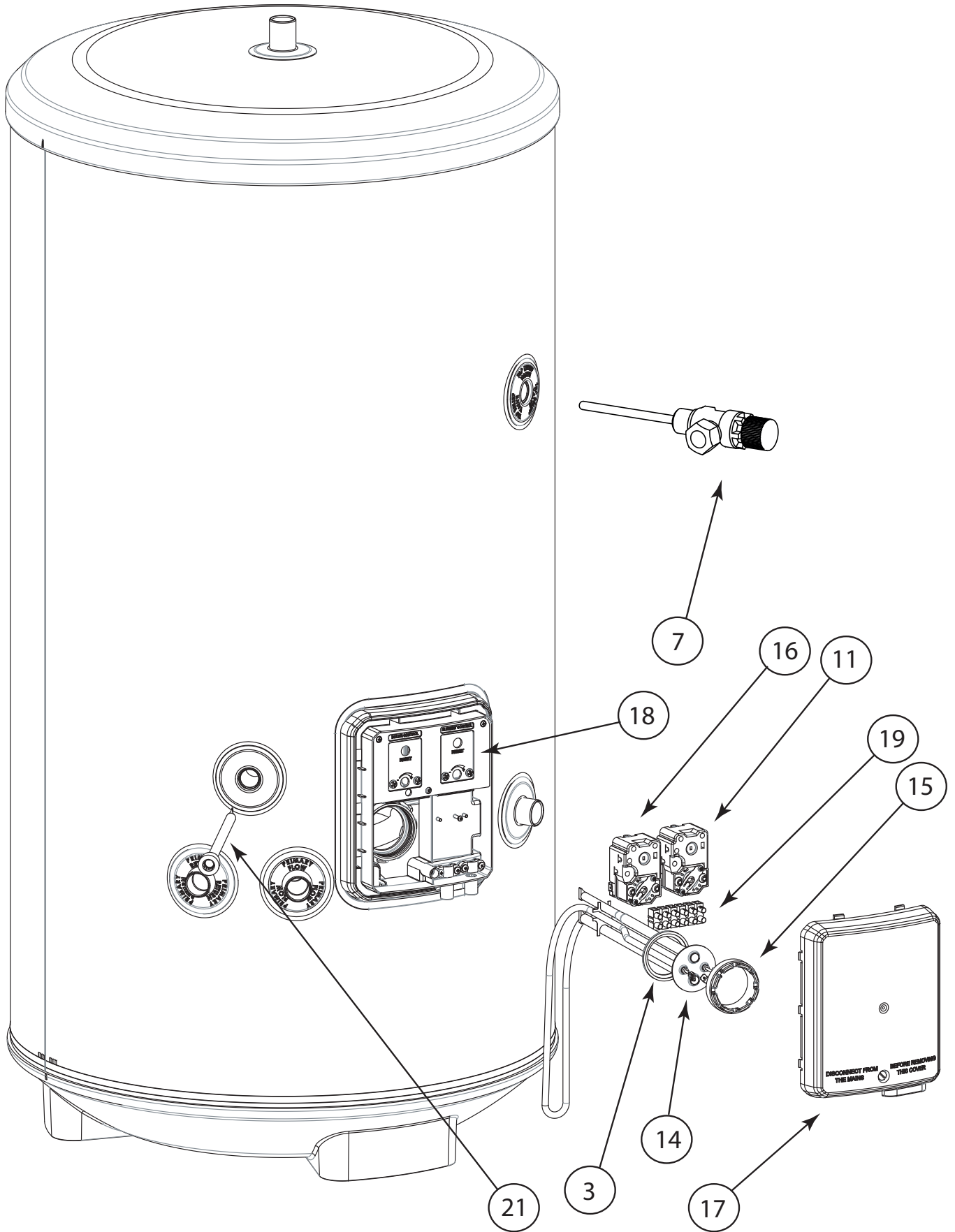
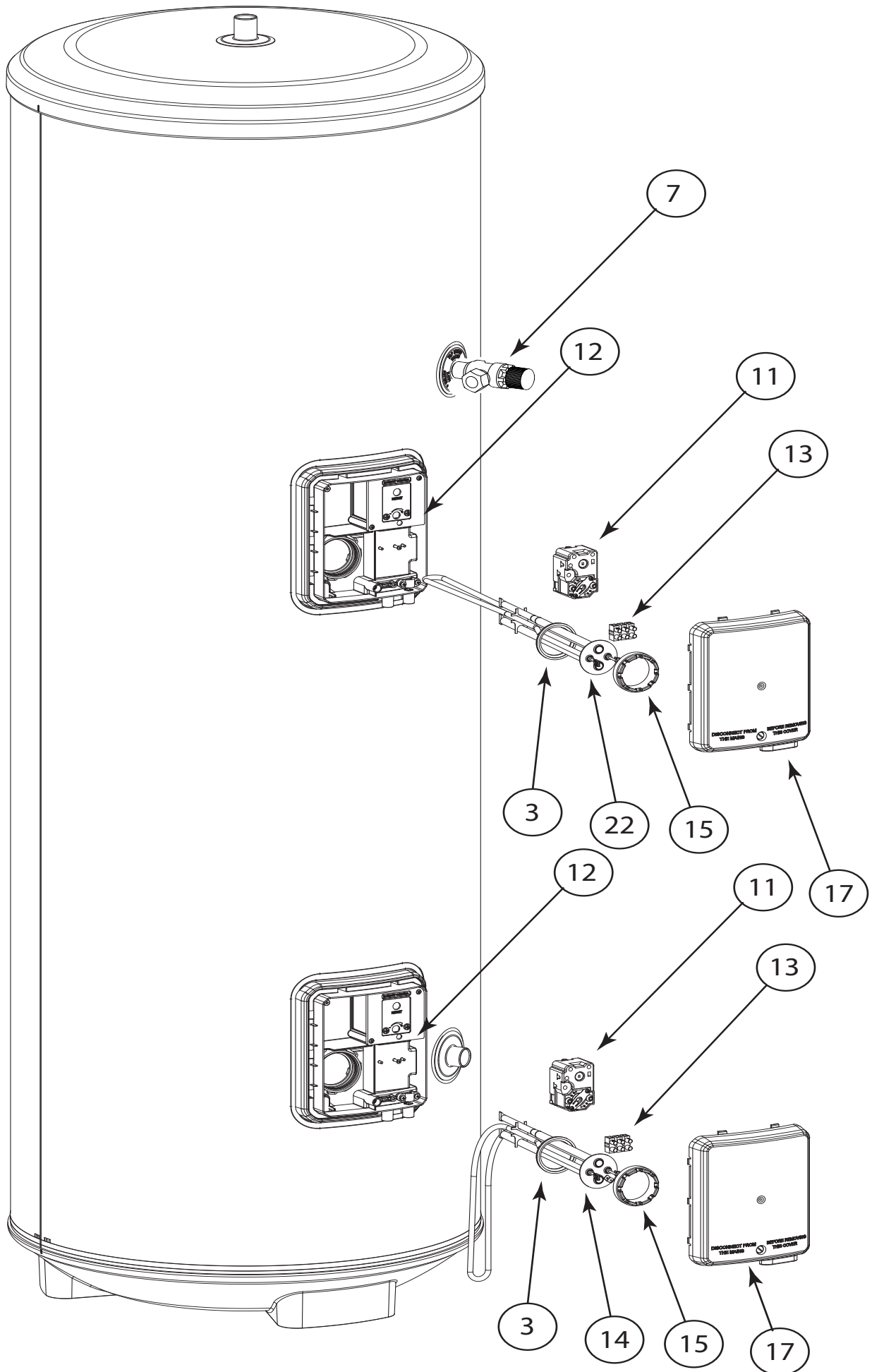

Figure 20: Direct controls - exploded view



Spares Stockists

Advanced Water Co.Ltd.
Unit D5 Enterprise Way
Vale Park, Evesham
Worcs WR11 1GS
Tel: 01386 760066
Fax: 01386 760077

Electric Water Heating Co.
2 Horsecroft Place
Pinnacles
Harlow
Essex CM19 5BT
Tel: 0845 0553811
E-Mail: sales@ewh.co.uk

SPD

Special Product Division
Units 9 & 10
Hexagon Business Centre
Springfield Road
Hayes
Middlesex UB4 0TY
Tel: 020 8606 3567

Parts Center
Tel: 0845 270 9800
www.partscenter.co.uk

Newey & Eyre
Unit 3-5 Wassage Way
Hampton Lovett Ind. Estate
Droitwich, Worcestershire WR9 0NX
Tel: 01905 791500
Fax: 01905 791501

UK Spares Ltd
Unit 1155
Aztec West
Almondsbury
Bristol BS32 4TF
Tel: 01454 620500

William Wilson Ltd
Unit 3A
780 South Street
Whiteinch
Glasgow G14 0SY
Tel: 0141 434 1530

Alternatively contact your local supplying merchant or
wholesale branch

MAINS PRESSURE HOT WATER STORAGE SYSTEM COMMISSIONING CHECKLIST

This Commissioning Checklist is to be completed in full by the competent person who commissioned the storage system as a means of demonstrating compliance with the appropriate Building Regulations and then handed to the customer to keep for future reference.

Failure to install and commission this equipment to the manufacturer's instructions may invalidate the warranty but does not affect statutory rights.

Customer Name _____ Telephone Number _____

Address _____

Cylinder Make and Model _____

Cylinder Serial Number _____

Commissioned by (print name) _____ Registered Operative ID Number _____

Company Name _____ Telephone Number _____

Company Address _____

Commissioning Date _____

To be completed by the customer on receipt of a Building Regulations Compliance Certificate*:

Building Regulations Notification Number (if applicable) _____

ALL SYSTEMS PRIMARY SETTINGS (indirect heating only)

Is the primary circuit a sealed or open vented system? _____ Sealed Open

What is the maximum primary flow temperature? _____ °C

ALL SYSTEMS

What is the incoming static cold water pressure at the inlet to the system? _____ bar

Has a strainer been cleaned of installation debris (if fitted)? _____ Yes No

Is the installation in a hard water area (above 200ppm)? _____ Yes No

If yes, has a water scale reducer been fitted? _____ Yes No

What type of scale reducer has been fitted? _____

What is the hot water thermostat set temperature? _____ °C

What is the maximum hot water flow rate at set thermostat temperature (measured at high flow outlet)? _____ l/min

Time and temperature controls have been fitted in compliance with Part L of the Building Regulations? _____ Yes

Type of control system (if applicable) _____ Y Plan S Plan Other

Is the cylinder solar (or other renewable) compatible? _____ Yes No

What is the hot water temperature at the nearest outlet? _____ °C

All appropriate pipes have been insulated up to 1 metre or the point where they become concealed _____ Yes

UNVENTED SYSTEMS ONLY

Where is the pressure reducing valve situated (if fitted)? _____

What is the pressure reducing valve setting? _____ bar

Has a combined temperature and pressure relief valve and expansion valve been fitted and discharge tested? _____ Yes No

The tundish and discharge pipework have been connected and terminated to Part G of the Building Regulations _____ Yes

Are all energy sources fitted with a cut out device? _____ Yes No

Has the expansion vessel or internal air space been checked? _____ Yes No

THERMAL STORES ONLY

What store temperature is achievable? _____ °C

What is the maximum hot water temperature? _____ °C

ALL INSTALLATIONS

The hot water system complies with the appropriate Building Regulations _____ Yes

The system has been installed and commissioned in accordance with the manufacturer's instructions _____ Yes

The system controls have been demonstrated to and understood by the customer _____ Yes

The manufacturer's literature, including Benchmark Checklist and Service Record, has been explained and left with the customer _____ Yes

Commissioning Engineer's Signature _____

Customer's Signature _____

(To confirm satisfactory demonstration and receipt of manufacturer's literature)

*All installations in England and Wales must be notified to Local Authority Building Control (LABC) either directly or through a Competent Persons Scheme. A Building Regulations Compliance Certificate will then be issued to the customer.



Commissioning & service records

SERVICE RECORD

It is recommended that your hot water system is serviced regularly and that the appropriate Service Record is completed.

Service Provider

Before completing the appropriate Service Record below, please ensure you have carried out the service as described in the manufacturer's instructions.

SERVICE 1 Date _____
Engineer Name _____
Company Name _____
Telephone Number _____
Comments _____

Signature _____

SERVICE 2 Date _____
Engineer Name _____
Company Name _____
Telephone Number _____
Comments _____

Signature _____

SERVICE 3 Date _____
Engineer Name _____
Company Name _____
Telephone Number _____
Comments _____

Signature _____

SERVICE 4 Date _____
Engineer Name _____
Company Name _____
Telephone Number _____
Comments _____

Signature _____

SERVICE 5 Date _____
Engineer Name _____
Company Name _____
Telephone Number _____
Comments _____

Signature _____

SERVICE 6 Date _____
Engineer Name _____
Company Name _____
Telephone Number _____
Comments _____

Signature _____

SERVICE 7 Date _____
Engineer Name _____
Company Name _____
Telephone Number _____
Comments _____

Signature _____

SERVICE 8 Date _____
Engineer Name _____
Company Name _____
Telephone Number _____
Comments _____

Signature _____

SERVICE 9 Date _____
Engineer Name _____
Company Name _____
Telephone Number _____
Comments _____

Signature _____

SERVICE 10 Date _____
Engineer Name _____
Company Name _____
Telephone Number _____
Comments _____

Signature _____

Warranty

The Baxi Warranty provides unrivalled levels of customer support and peace of mind in the unlikely event that a problem arises from a manufacturing defect. It is supported by a large nationwide team of company-employed field-based engineers and our own call centre, which is open 363 days a year.

The Baxi Warranty covers Baxi cylinders against corrosion for 25 years from date of original purchase.

The cold water inlet valve (and expansion vessel, where supplied) is covered by a five year warranty from the date of purchase of the Baxi product, that includes both parts and labour. All other components, including any other valves, fittings and controls supplied with the Baxi Assure are covered by a two year warranty from the date of purchase of the Baxi product, that includes both parts and labour.

Incoloy immersion heaters (where fitted) are covered by a two year warranty.

Outside of the UK

These warranties are valid for installations within the United Kingdom.

For installation in the Republic of Ireland please contact Baxi Potterton Myson (Ireland) Limited on 00353 (0) 1 4590870

This warranty is valid provided that:

- The Baxi product has been installed by a competent installer in accordance with the instructions contained in the installation instructions and in compliance with all relevant laws, guidance, codes of practice and regulations in force at the time of installation.

- The Baxi product has not been modified or tampered with in any way, other than by a Baxi Customer Support approved engineer.

- The Baxi product has not been subject to damage by scale.

- The Baxi product and any part or parts of the Baxi product (whether factory fitted or otherwise) have not been repaired or replaced other than by a Baxi Customer Support approved engineer and any replacement parts used on the Baxi product are authorised Baxi spare parts.

- The Baxi product has not been subject to misuse or neglect.

- The Baxi product has only been used for the storage of wholesome water. Should another substance be put through the product, the warranty will be invalid unless it is part of a disinfectant procedure carried out in accordance with BS EN 806.

- The Baxi product has not been subjected to frost or freezing temperatures.

- The Benchmark™ commissioning checklist service record, included in the Baxi installation instructions has been completed.

- Regular maintenance has been carried in accordance with the requirements set out in the maintenance section of the installation instructions, by a competent person, an approved engineer from Baxi or any other part of the Baxi Groups Customer Support approved engineering team.

- Access is available, at reasonable times and upon reasonable notice, to the Baxi product to allow for any inspection repair or replacement.

- The product is registered within 60 days of purchase. This can be done by telephone, online or by using the registration form provided with the product.

- Evidence of purchase (for example a receipt or delivery note) and date of supply is submitted when making a claim.

- The Baxi product has not been affected by any cause beyond our reasonable control including, without limitation: an act of God, explosion, flood, fire or accident; war or civil disturbance; strike, industrial action or stoppages of work; any form of government intervention; a third party act or omission including theft or malicious damage; failure by you to give us a correct delivery address or notify us of any change of address.

If any of the following situations occur, the Baxi Warranty will NOT apply:

- Any wilful or accidental damage caused by your negligence

- Damage caused as a result of scale.

- Installation not in line with the installer and user manuals provided,

- Failure to comply with installation instructions (whether oral or in writing),

- Misuse of the Baxi product or alteration of the Baxi product not in accordance with the requirements set out above.

- Defects which are reported to us outside of the warranty period on 0344 8711535 or Megafloservice@baxi.co.uk

- Any third party repair or replacement costs unless those costs have been agreed and authorised by Baxi Customer Support or Baxi in writing prior to incurring the costs.

Claims

Defects should be reported to us as soon as you are aware of them. Please report defect to us by contacting 0344 871 1535 or heatrae.bcs@baxi.co.uk.

Notes

Baxi accepts no liability for any third party damage.

These warranties do not affect your statutory rights and remedies in relation to the Baxi products.

Annual service

Annual services are available from Baxi Customer Support, the service division of Baxi.

Please contact Baxi Customer Support on 0344 871 1535 for details.

Baxi 25 year warranty is the period during which the first owner of the Baxi or a new build home continues to own the property. Should the property be sold, the new owner and any subsequent owners will receive a 25 year warranty from the date the original owner purchased the Baxi or a new home with a Baxi installed.

The Baxi warranty is conditional on the installation being carried out in accordance with the installation instructions supplied with the product. These warranties do not affect your statutory rights. Full terms and conditions of these warranty packages are available on request or via www.heatraesadia.com/

Baxi may introduce modifications to their products from time to time. Consequentially the details given in this brochure are subject to alteration without notice.

Contacts

Specification Advice Hotline

T: 0344 871 1535 (option 1, then option 2)

E: specifier@heatraesadia.com

www.heatraesadia.com

Heatrae Sadia is a trading name of:

Baxi Heating UK Limited,

Brooks House,

Coventry Road,

Warwick,

CV34 4LL

NOTES:

BAXI

Customer service

Telephone: 0344 8711535
E-mail: heatrae.bcs@baxi.co.uk

Heatrae Sadia
Brooks House,
Coventry Road,
Warwick,
CV34 4LL

Important notice to installations outside of the UK.

References to legislation, legal requirements, regulations, building regulations benchmark, spares stockists, guarantees and warranty are ONLY APPLICABLE WITHIN THE UK.

For local legislation, legal requirements, regulations, building regulations outside of the UK, contact your local Authority.

For spares stockists, guarantees and warranty outside the UK, contact your local supplier.



The HWA Charter's Code of Practice requires that all members adhere to the following:

- To supply fit for purpose products clearly and honestly described
- To supply products that meet, or exceed appropriate standards and building and water regulations
- To provide pre and post sales technical support
- To provide clear and concise warranty details to customers

